

# TASVIRIY SAN'AT

Umumiy o'rta ta'lim maktablarining  
3-sinfi uchun darslik

Tuzatilgan va to'ldirilgan to'rtinchi nashri

*O'zbekiston Respublikasi Xalq ta'limi vazirligi  
tomonidan nashrga tavsiya etilgan*

TOSHKENT  
«YANGIYO'L POLIGRAF SERVIS»  
2016

## Mualliflar:

M. ISOQOVA, R. HASANOV, B. HAYDAROV,  
A. SULAYMONOV, S. JUMANIYOZOVA, B. AZIMOV

**Taqrizchilar:** *R. Xudayberganov* – O‘zbekiston xalq rassomi, K. Behzod nomidagi Milliy rassomlik va dizayn instituti professori.

*N. Boymurodova* – Respublika ta‘lim markazi bosh metodisti.

A. Salixova – Toshkent shahar Olmazor tumanidagi 159-umumiy o‘rta ta‘lim maktabining tasviriy san‘at fani o‘qituvchisi.

Z. Hoshimova – Toshkent shahar Olmazor tumanidagi 16-umumiy o‘rta ta‘lim maktabining tasviriy san‘at fani o‘qituvchisi.

## SHARTLI BELGILAR:



– faollashtiruvchi savollar va topshiriqlar



– o‘rganish va yodda tutish zarur



– amaliy mashq va topshiriqlar



– uyga berilgan topshiriqlar



– qiziqarli topshiriqlar



– iqtidorli bolalar uchun topshiriqlar



– takrorlash uchun savol va topshiriqlar



– dars tugadi

**Respublika maqsadli kitob jamg‘armasi  
mablag‘lari hisobidan chop etildi.**

ISBN 978-9943-309-72-2 © «Yangiyo‘l poligraf servis», 2008, 2010, 2014, 2016.

© M. Isoqova, S. Jumaniyozova, 2010, 2016.

## **BOLALAR IJODIYOTI UYI — SEVIMLI MASKAN**

Yurtimizda tasviriy va amaliy san'atga ixlosmand o'quvchilar uchun maktab ta'limiga qo'shimcha tarzda «Barkamol avlod» bolalar markazlarida turli yo'nalishdagi to'garaklar faoliyat ko'rsatadi.



**RASM ISHLASH UCHUN JOY HOZIRLASH  
VA NARSALARNING O'LCHAMINI ANIQLASH**

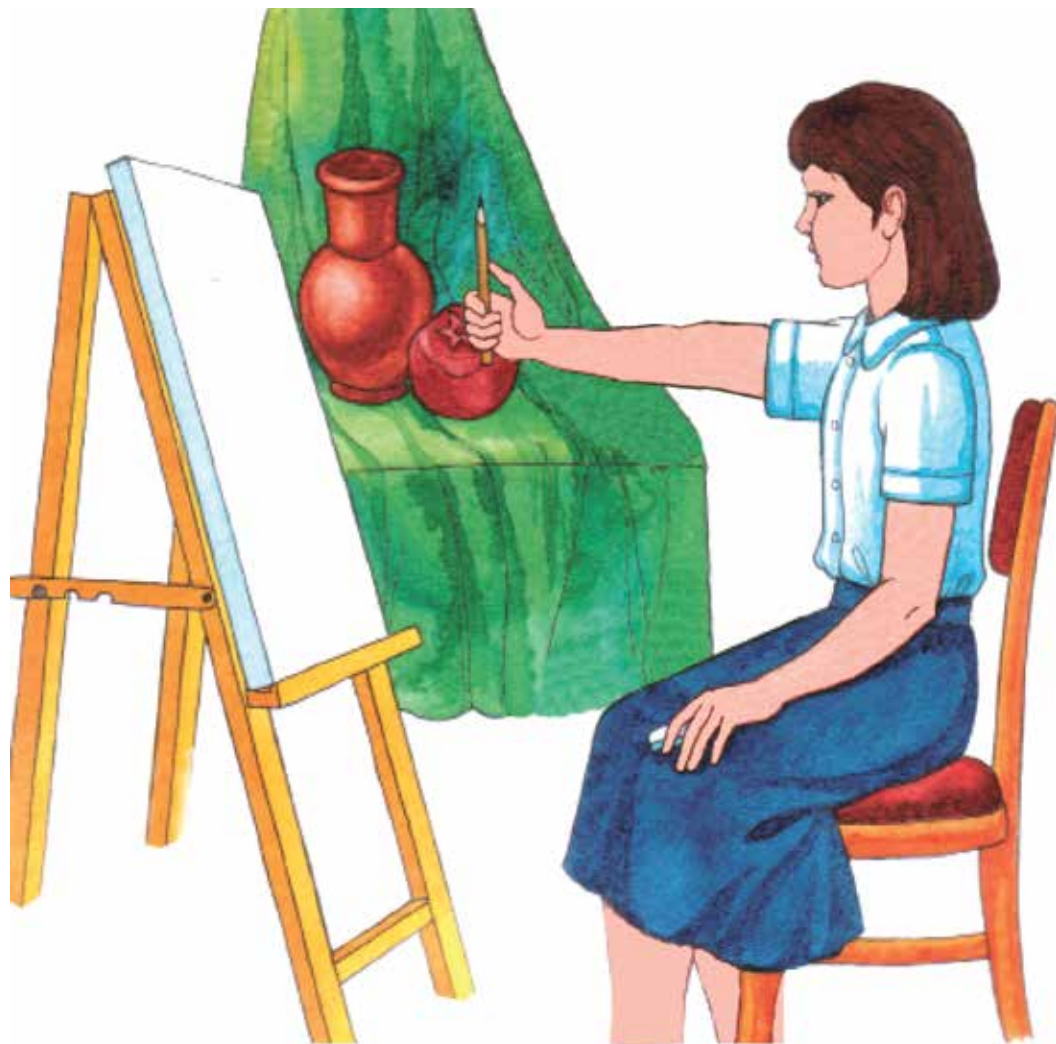

Rasm ishlayotganda shunday o'tiringki, yorug'lik nuri siz kuzatayotgan naturaga chap tomondan tushsin.



# I CHORAK

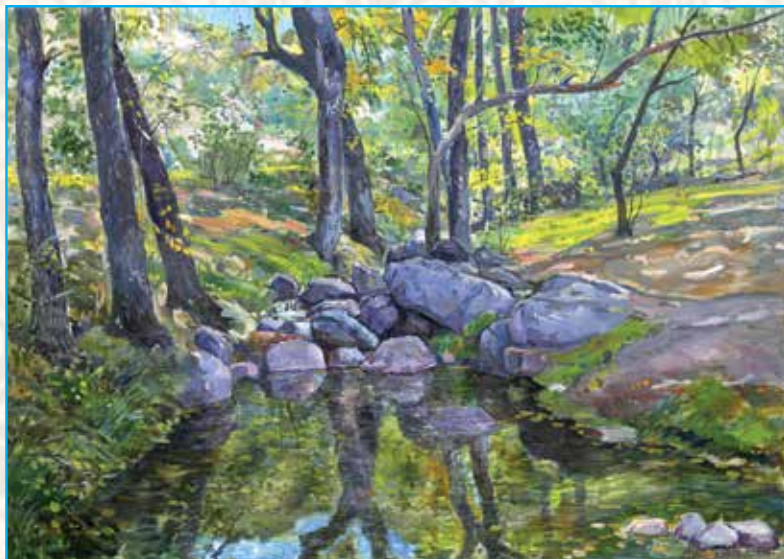

G'. Abdurahmonov. *Oqtoshdagi buloq.*

## **Bu chorakda siz:**

- yoz va kuz manzaralari rasmini ishlashni;
- kontrast ranglarni va ulardan foydalanishni;
- naturaga qarab rasm ishlashni;
- to'rtburchak va yo'lsimon shakllarda naqshlar ishlashni o'rganasiz;
- amaliy san'at ustalari, rassomlar va haykaltaroshlarning hayoti va ijodi bilan tanishasiz;
- turlicha mavzuda haykal va relyeflar ishlaysiz.

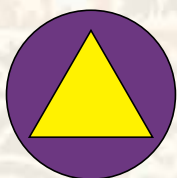

1

## «O‘ZBEKISTON — MENING VATANIM» MAVZUSIDA RASM ISHLASH

O‘zbekiston — mening Vatanim. Unda bizning ajdodlarimiz yashab kelganlar. Hozirda biz uning musaffo havosidan nafas olib, zilol suvlaridan ichib, dalalarida yetishtirilgan noz-ne‘matlaridan bahramand bo‘lyapmiz.



Yuqoridagi rasmda Vatanimiz poytaxti — Toshkentdagi Mustaqillik maydonida o‘rnatilgan haykallar kompozitsiyasini ko‘ryapsiz. Bu kompozitsiya «Ezgulik monumenti» deb ataladi.



1. Bu haykallarning qanday ramziy ma‘nolari bor?
2. Ular haqida gapirib bering.



O'zbekiston zamonaviy shaharlari, fayzli qishloqlari, adir-u tog'lari, serhosil bog'lari bilan go'zal. Rassomlar ularni o'zgacha ilhom bilan tarannum etadilar. Rassom G'ofur Abdurahmonovning «Tog'lar» nomli asarida tog'larda kuz manzarasi mahorat bilan tasvirlangan.



G'. Abdurahmonov. Tog'lar.



1. Rasmlar asosida Vatanimiz tabiati haqida so'zlab bering.



Go'zal tabiat manzarasi.



1. Yuqoridagi rasmda qanday ko'rinish tasvirlangan? U haqda gapirib bering.
2. Bayram kayfiyati qanday ranglarda tasvirlanadi?





Endi yuqoridagi rasmlarda kuzatgan manzaralarni eslab «O‘zbekiston – mening Vatanim» mavzusida rasm ishlang.



### Mo‘yqalamlar.

Bo‘yalayotgan sirtning katta-kichikligiga qarab yo‘g‘on, o‘rtacha va ingichka mo‘yqalam tanlanadi.



### Mo‘yqalamdan foydalanish qoidalari:

- mo‘yqalamni suvda qoldirmang;
- mo‘yqalamni yangi rangga botirishdan oldin uni suvda yuvib oling;
- mo‘yqalamni quruq saqlang.



1. «O‘zbekiston – mening Vatanim» mavzusida ishlanayotgan rasmni oxiriga yetkazing.

2\*. «Mustaqillik bayrami» mavzusida rasm ishlang.



2

«YOZ O‘TDI SOZ»  
MAVZUSIDA RASM ISHLASH

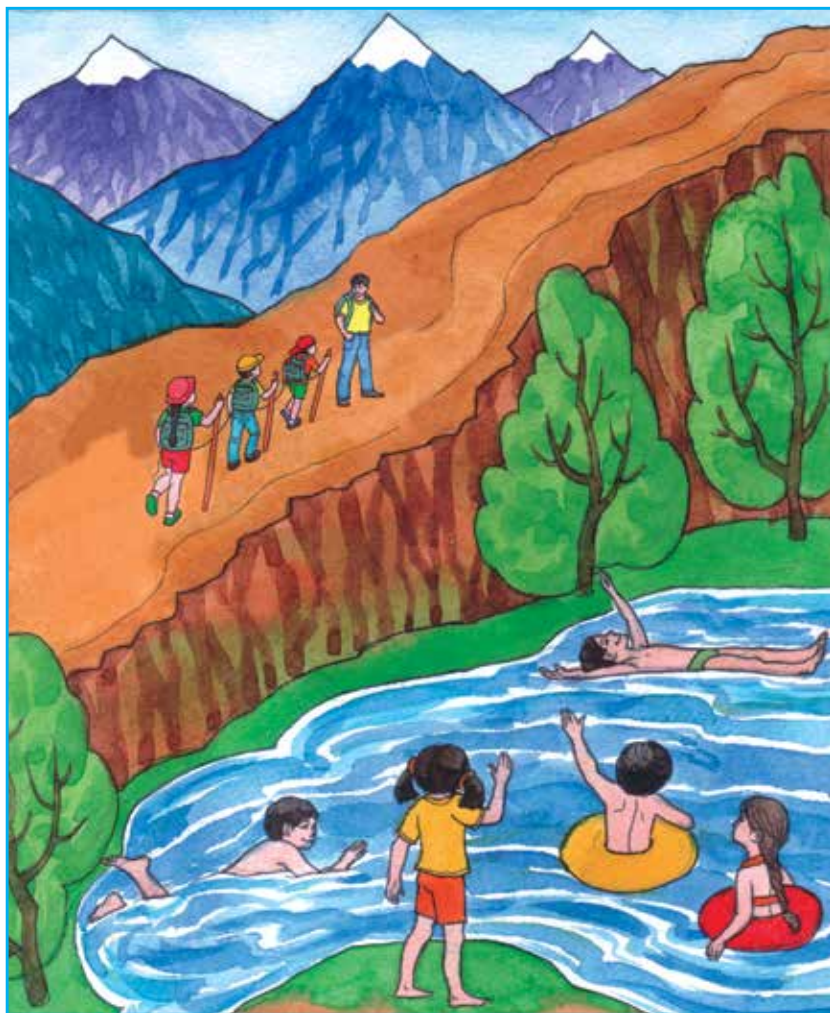

1. Rasm asosida tengdoshlaringiz yozgi ta'tilni qanday o'tkazgani haqida hikoya qilib bering.
2. Rassom tog' manzarasini ishlashda qaysi ranglardan foydalangan?

Yoz oylarida, odatda, odamlar soya-salqin joylar, bog'lar va suv havzalariga yaqin tog'li maskanlarga borishni yaxshi ko'radilar. Rassom Sh. G'ofurovning «Tog'li ko'l» asarida shunday manzaralardan biri tasvirlangan. Siz undan ishlaydigan rasmingizda foydalanishingiz mumkin.



Sh. G'ofurov. *Tog'li ko'l*.



Narsalar kuzatuvchidan uzoqlashgan sari ularning o'lchamlari kichiklashib ko'rinadi, ranglari esa xiralashib boradi.



Yozgi taassurotlaringiz va kuzatgan rasmlaringiz asosida «Yoz o'tdi soz» mavzusida tabiat manzarasi tasvirlangan rasm ishlang.

### Tog'li manzara rasmini ishlash bosqichlari.

1



Tasvirni qog'ozga joylashtirish.

2



Qalamda xomaki ishlash.

3

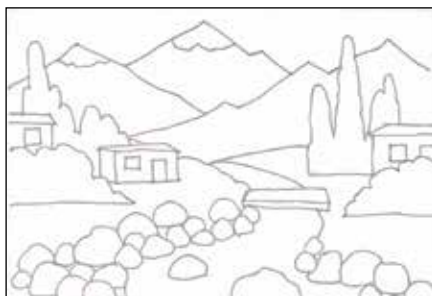

Tasvirni qalamda yakunlash.

4



Tasvirni bo'yash.



1. Sinfda ishlangan «Yoz o'tdi soz» mavzusidagi rasmni bo'yang.

2\*. «Bizning bog'» mavzusida rasm ishlang.





O'zbekistonimiz o'zining atlas matolari bilan mashhur. Ulardan turli-tuman kiyim-kechaklar tikiladi. O'zbekiston atlaslari rang-barangligi bilan ajralib turadi. Ularda ranglar jilosi aks etgan.



1. Yuqoridagi rasmlarda tasvirlangan atlas matolardagi shakllarga va ranglar jilosiga e'tibor bering.
2. Matolarda ishlatilgan ranglar nomini ayting.
3. Atlasda qo'llanilgan ranglarning kontrastligi, shakllarning tuzilishini tahlil qiling.

## Ranglar halqasi.



## Ranglar hosil qilish usuli.

Turli rangdagi bo'yoqlarni o'zaro aralashtirib yangi rang hosil qilinadi. Ular atlas matosi uchun rang tanlashda qo'llanishi mumkin. Atlas matosi uchun eskiz ishlash uchun imkoni boricha guash bo'yoqlaridan foydalanish tavsiya etiladi. Chunki guash bo'yog'i yuzani qoplash xususiyatiga ega. Akvarel bo'yoqlar esa shaffof bo'lgani sababli aniq ranglar hosil qilishi uchun bir necha marta rang berish lozim bo'ladi.

## Akvarel bo'yoq bilan ishlash.



Birinchi qurimasdan surtilgan bo'yoq o'zaro aralashib ketadi.



Birinchi qurigandan keyin surtilgan ikkinchi bo'yoq o'zaro aralashmaydi.



Bo'yoqqa qanchalik ko'p suv aralashtirilsa, u shuncha och tusga kirib boradi.





## Ranglarni hosil qilish.

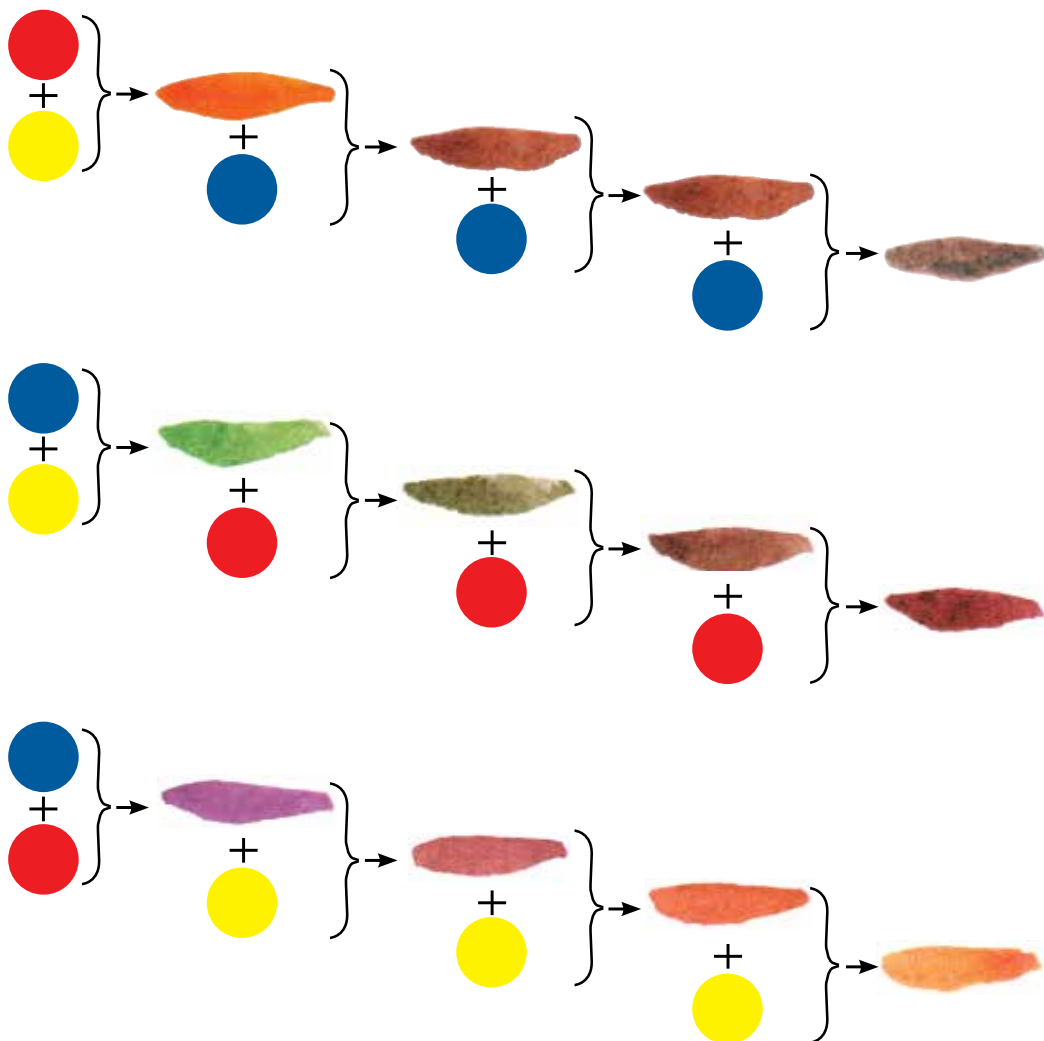

Yuqoridagi ko'rsatmalar asosida turli ranglarni hosil qiling va ulardan atlas kompozitsiyasida foydalaning.







«Tumor» nusxali xonatlas.



«Namozshomgul» nusxali xonatlas.

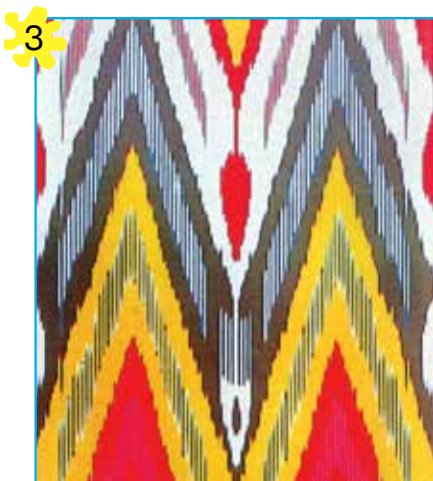

«Chaqirim tabdili» nusxali xonatlas.



«Qora qarg'a» nusxali xonatlas.



1. Yuqoridagi xonatlaslardan qaysi biri sizga yoqadi?
2. Xonatlaslarda qanday ranglar ishlatilgan?



## Atlas uchun kompozitsiya ishlash bosqichlari.

1

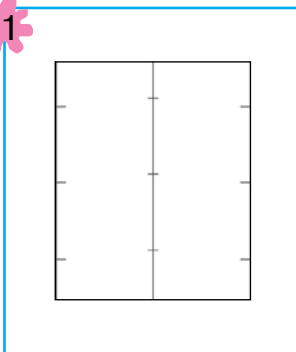

Tasvirni qog'ozga joylashtirish.

2

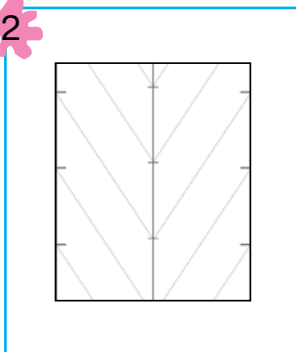

Qalamda xomaki ishlash.

3



Tasvirni qalamda yakunlash.

4



Och ranglarda bo'yash.

5

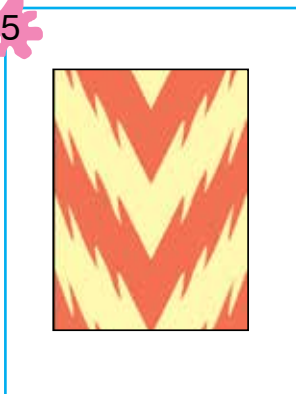

To'qroq ranglarda bo'yash.

6

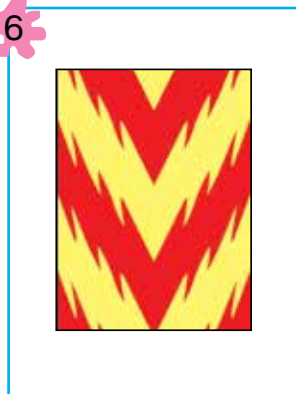

To'q ranglarda ishlov berish.



Yuqoridagi kabi atlas uchun mustaqil kompozitsiya islang.



1. Sinfda ishlangan atlas naqshini yakunlang.
2. Boshqa turdagi atlas uchun naqsh islang.



# 4

## YO'LSIMON SHAKLDA NAQSH ISHLASH



1. Har bir naqshda ishlatilgan bezak gullarini diqqat bilan kuzating va ularning nomini ayting.
2. Naqsh foni va bezak gullari ranglarini o'zaro taqqoslang.



Naqsh kompozitsiyasini hosil qilishda uning bezak gullari ma'lum me'yorlar asosida takrorlanishiga amal qiling. Bu naqqoshlikning asosiy qoidalaridan bo'lib, u «RITM» deb ataladi.

Naqsh bezak gullari va asosini tasvirlashda naqsh ustalari ko'pincha kontrast ranglardan foydalanadilar. Natijada, naqshlar jozibador va yorqin ko'rinadi.



**Kontrast ranglar** — o‘zaro qarama-qarshi ranglar.

Kontrast ranglar naqshlarda bezak gullari va fon rangining och to‘qligi bilan aniqlanadi. Kontrast ranglar faqat och-to‘qligi asosida emas, rang turlari (iliq, sovuq) orqali ham aniqlanadi.

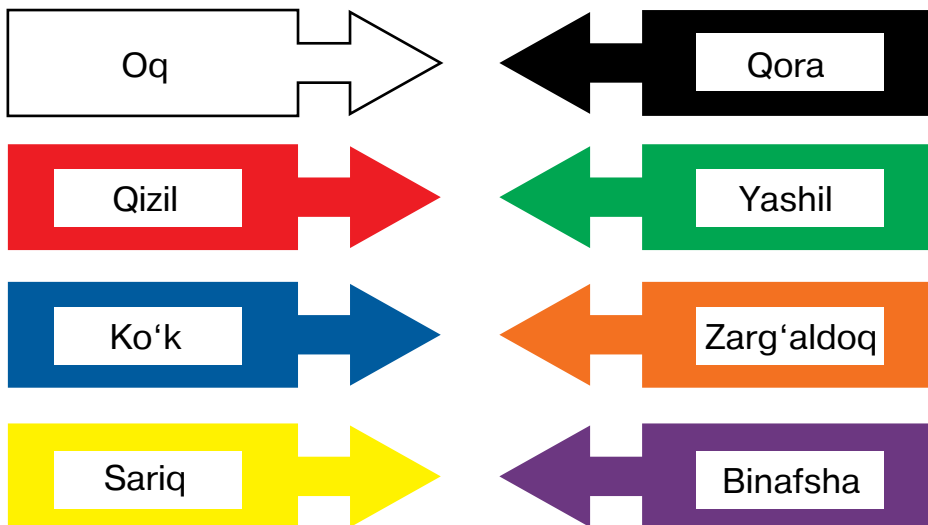

Bu ranglar yonma-yon ishlatilganda bir-birini yorqinroq ko‘rsatadi.



Kapalak qanotidagi kontrast ranglarni aniqlang.

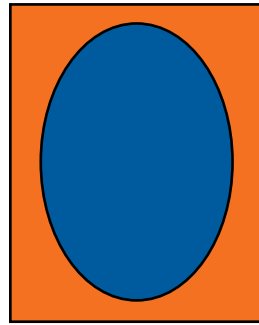
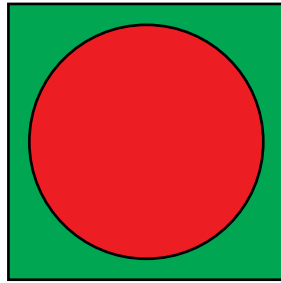
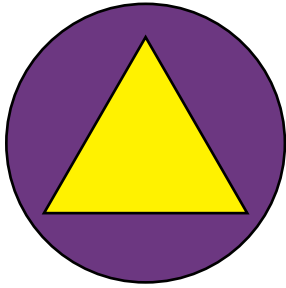

Bu rasmlarning qaysinisida kontrast (och-to'q) ranglar qo'llanilgan?

Kontrast ranglarning biri ikkinchisining asosida (fonda) yorqinroq ko'rinishiga e'tibor bering.

Naqsh ishlaganda uning foni va bezak gullarini bo'yashda kontrast ranglardan foydalansangiz, ranglar yanada yorqinroq ko'rinadi.

Bezak naqshlar axromatik ranglar bilan ham ishlanadi.



**Oq, kulrang** va **qora** ranglar — **axromatik** ranglar deb ataladi. Qolgan ranglar esa **xromatik** ranglar hisoblanadi.

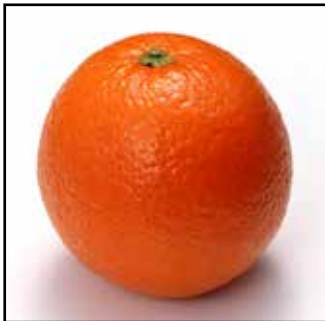

Axromatik rangdagi fon xromatik rangdagi narsalarni yanada yorqinroq ko'rsatadi.



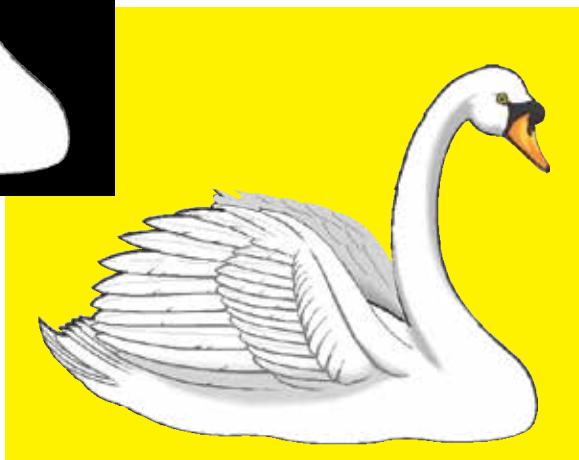

Oqqush qora fonda yorqin ko'rinadi. Sariq fonda esa unchalik yorqin ko'rinmaydi.



### Yo'lsimon naqshlar.

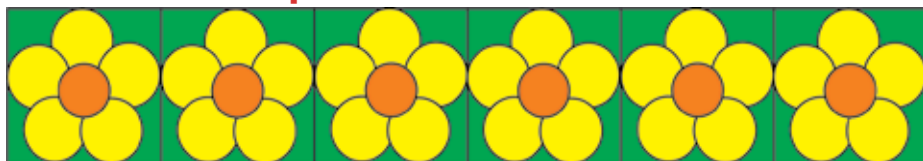

Bir xil rangdagi bezak gulli naqsh (oygul).

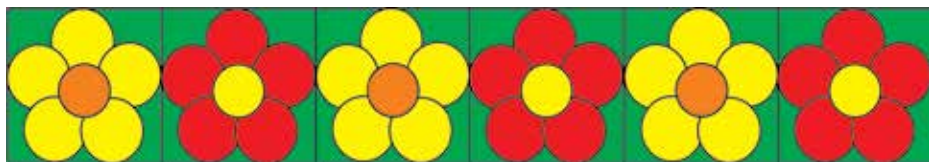

Ikki xil rangdagi bitta bezak gulli naqsh (oygul).



oygul

lola

oygul

lola

oygul

lola

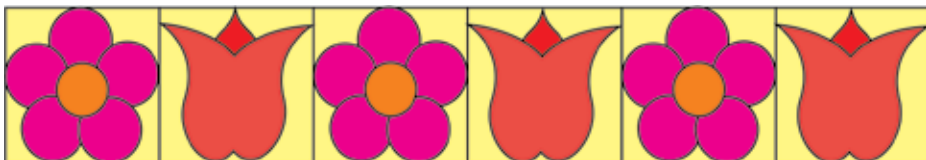

Ikkita bezak gulli naqsh.



**Ritm** — naqshda bezak gullarining takrorlanib yoki almashinib kelishidir.



Ikkita bezak gulli yo‘lsimon naqsh ishlang. Unda naqshning boshqa elementlaridan ham foydalanishga harakat qiling.



1. Quyidagi yo‘lsimon naqshlarda qaysi bezak gullaridan qanday tartibda foydalanilgan?

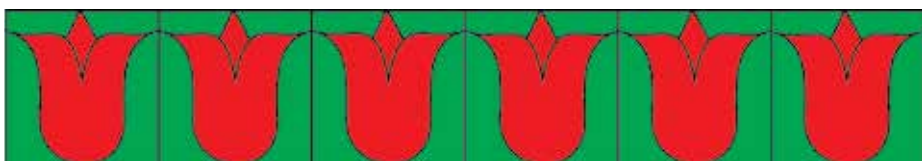



2. Naqsh asosi va bezak guli qanday ranglarga bo‘yalgani ma‘qul?

3. Kontrast ranglarni juft-jufti bilan sanab bering.  
 4. Barg rasmini tasvirlash uchun qanday rangdagi asos (fon) tanlangani ma'qul?



5. Noma'lum ranglarni toping.

1)  +  =   
 sariq ko'k

2)  +  =   
 qizil zarg'aldoq

3)  +  =   
 \_\_\_\_\_ ko'k binafsha

6. Quyidagi buyumlarning bezatilishida qanday naqshlardan foydalanilgan?







1. Ikkita bezak gulli naqshni akvarelda kontrast ranglarga bo'yang.
- 2\*. Ikkita bezak gulli va ranglari almashib keladigan naqsh ishlang.



Usta Yoqubjon Raufov  
(1888 – 1974)

Yoqubjon Raufov — naqqosh usta, O'zbekiston xalq rassomi. Naqqoshlik hunarini otasi usta Rauf Kalondan o'rgangan. Usta Yoqubjon Raufov respublikamizning qator shaharlaridagi jamoat binolarini bezashda boshchilik qilgan.



*Usta Yoqubjon Raufov ishlagan naqsh.*



O'lkamizda oltin kuz o'z sepini yoygan. Bog'larda olma, anor, nok, shaftoli, uzum, anjirlar, polizlarda tarvuz va qovunlar g'arq pishgan.

Kuzda eng go'zal bayramlarimizdan biri, «Hosil bayrami» o'tkaziladi.



«Hosil bayrami» haqida so'zlab bering.



Kuzgi mevalarni rangtasvir ustalari zo‘r maroq bilan tasvirlaydilar. Ular ishlagan rasmlar kishiga zavq-shavq bag‘ishlaydi. Siz ham mevalar rasmini ishlang.



## Anor rasmini ishlash bosqichlari.

1

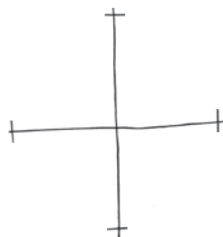

Tasvir o‘lchamlarini belgilash.

2

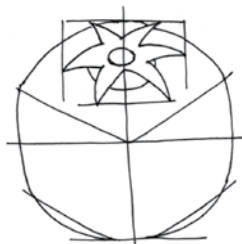

Qalamda xomaki ishlash.

3



Tasvirni qalamda yakunlash.

4



Och ranglarda bo‘yash.

5



To‘qroq ranglarda bo‘yash.

6



To‘q ranglarda ishlov berish.



## Olma rasmini ishlash bosqichlari.

1

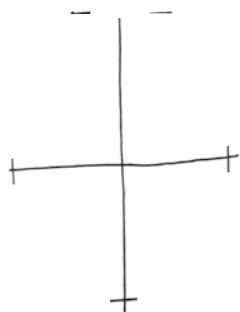

Tasvirni o'lchamlarini belgilash.

2



Qalamda xomaki ishlash.

3



Tasvirni qalamda yakunlash.

4



Och ranglarda bo'yash.

5



To'qroq ranglarda bo'yash.

6



To'q ranglarda ishlov berish.



Olma va anor rasmini o'ziga qarab ishlang.



1. Naturaga qarab rasm ishlaganda tasvir qog'oz yuzasiga qanday joylashtirilishi kerak?
2. Naturaga qarab rasm ishlaganda yana nimalarga e'tibor berish kerak?



1. Sinfda ishlagan rasmingizni oxiriga yetkazing.
- 2.\* «Mevalar» natyurmortini ishlang.



V. I. Ufimsev. *Baqlajonlar.*

**Ufimsev Viktor Ivanovich** (1899–1964) — O'zbekiston xalq rassomi. U o'zining «Moviy rumkali natyurmort», «Dala gullari», «Baqlajonlar» kabi natyurmortlari bilan mashhur.

6

## HAYKALTAROSHLIK. BALIQ RELYEFINI YASASH



*Haykaltarosh Ilhom va Kamol Jabborovlar. Toshkent shahrida o'rnatilgan Amir Temur haykali.*



*Relyeflar.*



1. Buyuk bobokalonimiz sohibqiron Amir Temur haqida nimalarni bilasiz?
2. Yuqoridagi fotosuratda tasvirlangan Amir Temur haykali haqida so'zlab bering.

**Ilhom Jabborov** — haykaltarosh, O‘zbekistonda xizmat ko‘rsatgan san‘at arbobi, O‘zbekiston Badiiy akademiyasining akademigi.

U Amir Temur, Al-Farg‘oniy, Jaloliddin Manguberdi, «Ona» kabi haykallar muallifi.

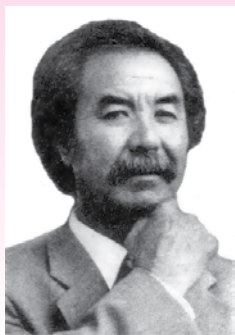

Ilhom Jabborov  
(1945- yilda  
tug‘ilgan)



*I. Jabborov. Al-Farg‘oniy*

Haykallar ishlanish uslubiga ko'ra 2 turga bo'linadi: har tomonlama aylanib ko'rishga mo'ljallangan va tekis sathga bo'rttirib ishlangan haykallar. Tekislikka bo'rttirib ishlangan haykallar relyefli haykallar deb ataladi. Tangalar, orden va medallar ham relyefli haykaltaroshlik namunasi hisoblanadi.



**Relyefli haykal** — tekis yuzaga (devorga) bo'rttirib ishlangan haykal.



L. Ryabsev, «Bahor keldi».





## Relyefli haykal ishlash bosqichlari.

1



Plastilinni (loyni) taxtachaga ma'lum qalinlikda tekis yotqizish.

2



Ishlanadigan haykal shaklini chizib olish.

3



Ishlanadigan haykal shaklini kesish.

4



Relyefga yakuniy ishlov berish.



Baliqning relyefli haykalini ishlang.



1. Relyefli haykal deb nimaga aytiladi?
2. Relyefli haykal ishlash bosqichlarini ayting.
3. Relyefli haykaltaroshlikka misollar keltiring.



1. Baliqning relyefli haykalini ishlashni oxiriga yetkazing.
- 2.\* Xo'rozning relyefli haykalini ishlang.



Buyumlar yo'lsimon, doira, kvadrat shakldagi naqshlar bilan bir qatorda to'rtburchak shakldagi naqshlar bilan ham bezatiladi. Ayniqsa, kashtachilikda ulardan keng foydalaniladi. Palak, so'zana, choyshab, kirpech, zardevor kabi kashtachilik buyumlarida o'simliksimon tasvirlar, shox, gulband, guldastalar ko'p uchraydi. Shuningdek, to'rtburchak shakldagi naqshlar naqqoshlik, yog'och o'ymakorligi, ganch o'ymakorligida ham qo'llaniladi.



1. Yuqoridagi rasmda tasvirlangan san'at namunalari amaliy san'atning qaysi turlariga mansub?
2. Ularni bezashda qanday naqsh turlari va bezak gullaridan foydalanilgan?

To'rtburchak shaklli naqsh namunalari.

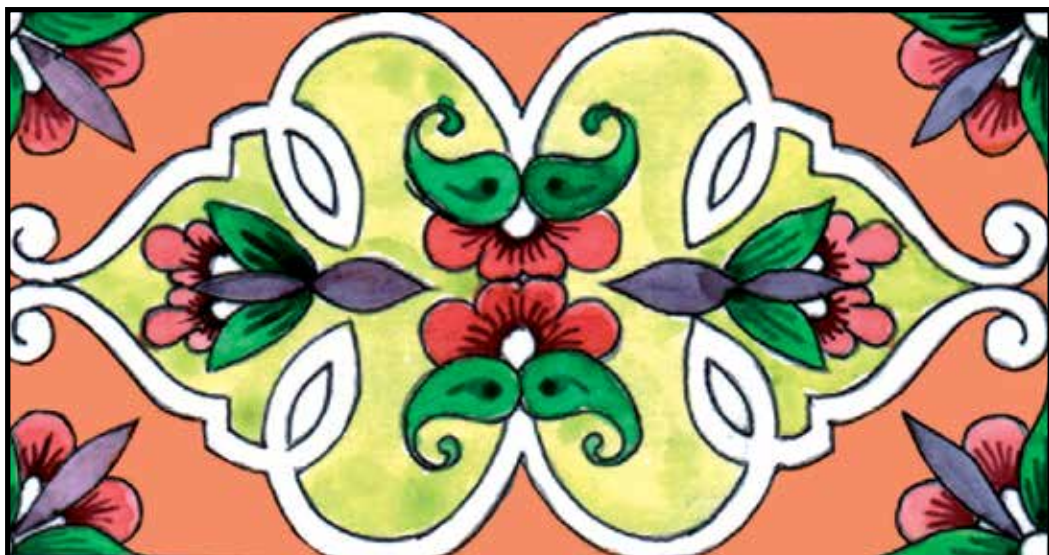

1. Yuqoridagi to'rtburchak shaklli naqsh namunalarida qanday bezak gullari bor?



**Buyumlarni bezashda ko'proq quyidagi bezak gullari ishlatiladi:**



barg



bodom



uch barg



ko'p barg



garmdori



lolagul



oygul



paxtagul



bofta



marg'ula





**To'rtburchak shaklli naqsh namunalari. Ulardan o'z ishingizda foydalaning.**

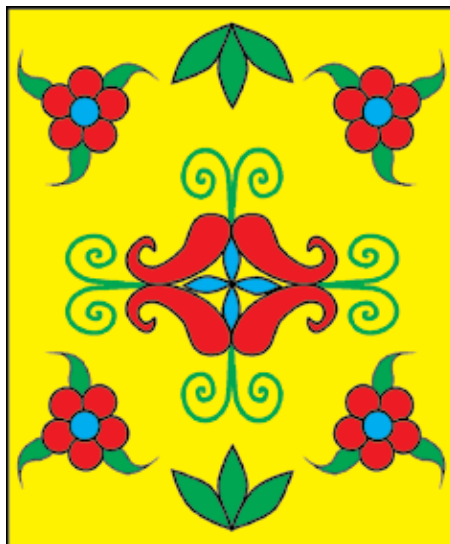

Endi naqsh kompozitsiyasini ishleng.



**Naqshlardagi bezak gullarini turlicha joylashtirish mumkin. «+» belgi bilan «oygul» oʻrni, «-» belgi bilan «barg» oʻrni belgilangan.**

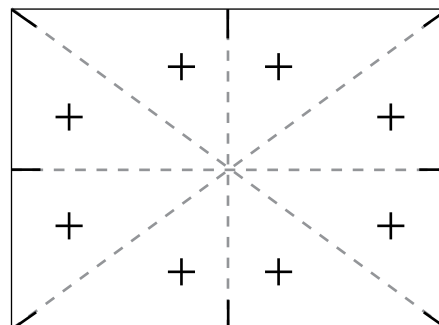
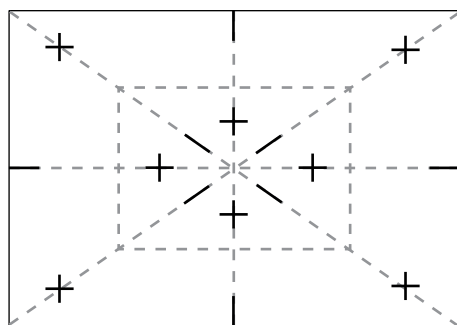
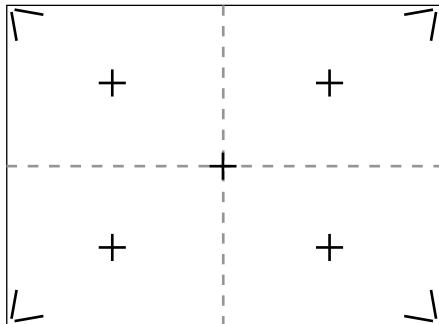
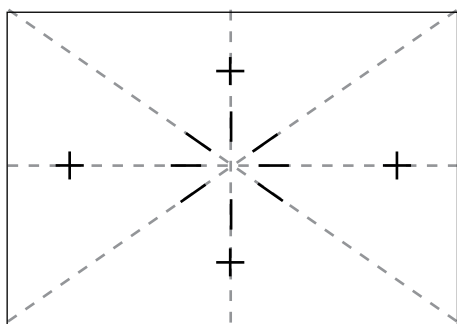

1. Sariq rangli qogʻoz varagʻini 8 qavat qilib buklab, «oygul» naqsh bezak gulini chizib oling.
2. Buklangan qogʻozni chizilgan gul bezagi boʻyicha qirqing. Natijada 8 ta «oygul» naqsh bezagi paydo boʻladi.
3. Shunga oʻxshash yashil rangli qogʻozdan 8 ta «barg» bezak gulini ham qirqib oling.
4. Yuqorida berilgan naqsh tarxlaridan birini tanlang. Qirqib olingan bezak gullarini qizil rangli qogʻoz ustiga joylashtirib, toʻrtburchakli naqsh ishleng.



1. Yuqoridagi buyumlarda qanday bezak gullari ishlatilgan?
2. Ulardagi yo'lsimon naqshlarni toping.



1. Sinfda ishlangan to'rtburchak shaklidagi naqshni oxiriga yetkazing.
- 2\* To'rtburchak shaklidagi gilam uchun naqsh ishlang.



O‘zbekiston – tabiati go‘zal yurt. Ayniqsa, kuz faslida yurtimiz tabiati o‘zgacha go‘zallik kasb etadi. Shuning uchun ham manzarachi rassomlar kuz tasviriga oid ko‘plab asarlar yaratganlar. Nikolay Karaxan, Rahim Ahmedov, Zokir Inog‘omov, G‘ofur Abdurahmonovlar shular jumlasidandir.



G‘. Abdurahmonov. *Kuz.*

Rassom G‘ofur Abdurahmonov kuz mavzusini tasvirlash uchun sariq, zarg‘aldoq va qizil ranglardan o‘rinli foydalangan.





1. G'. Abdurahmonovning «Kuz» nomli asarini yaxshilab kuzating. Unda nimalar tasvirlangan? Asarda qaysi ranglardan foydalanilgan?

2. «Tog'da kuz» mavzusida hikoya tuzing.

Rangtasvir kompozitsiyasi asosiy va yordamchi elementlardan (bo'laklardan) iborat.

Asosiy element odatda o'rtada tasvirlanadi. Qolgan yordamchi elementlar asosiy element atrofiga joylashtiriladi.



Bu yerda asosiy element — kungaboqar, yordamchi elementlar — asalarilar. Agar kungaboqar olib tashlansa, kompozitsiya o'z mazmunini yo'qotadi.

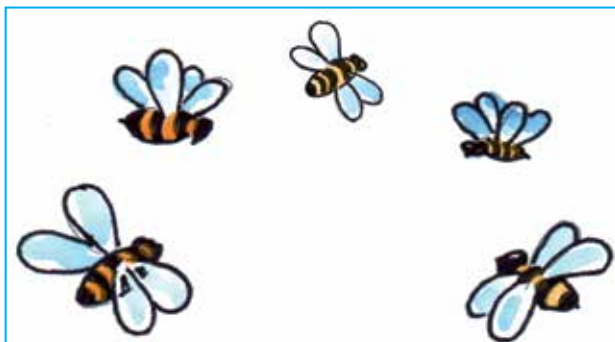



1. Kuz fasli odatda qaysi ranglar bilan tasvirlanadi? Quyidagi rasmlarning qaysi birida kuz fasli tasvirlangan?
2. Kompozitsiyaning qanday elementlari bor? 3-rasmdagi asosiy va yordamchi elementlarni aniqlang.

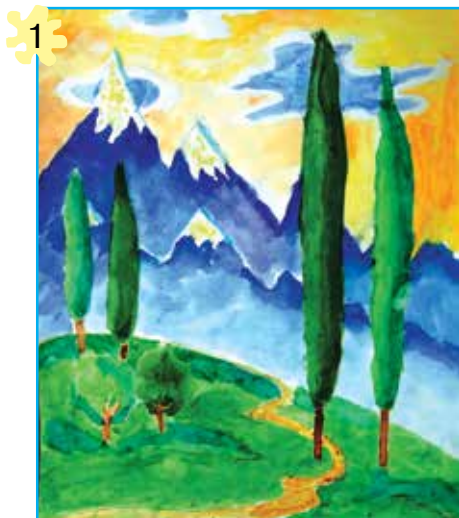



## «Togʻda kuz» mavzusida rasm ishlash bosqichlari.

1



Qogʻoz yuzasida narsalarni umumiy tarzda tasvirlash.

2



Rasmda narsalar tasvirini aniqlashtirish.

3



Rasmni och ranglarda boʻyash.

4



Rasmdagi koʻrinishlarning aniq tasvirini ishlash.



1. «Togʻda kuz» mavzusida kompozitsiya ishlang.



1. Sinfda ishlangan «Tog‘da kuz» mavzusidagi rasmni oxiriga yetkazing.

2\*. «Kuz» mavzusida mustaqil rasm ishlang.



**Inog‘omov Zokir** (1919–1996) — O‘zbekiston xalq rassomi. Uning asarlarida qahramonlarning qiyofalari jonli, hayotiy ifodalanganligi bilan diqqatga sazovor. «Onalik», «Kuz», «Dalada nonushta», «Xirmonda», «Mosh hosili», «Orol» va boshqalar Inog‘omovning mashhur asarlari hisoblanadi.



Z. Inog‘omov. *Choyga*.

## I. Test savollari:

1. Qaysi qatorda kontrast ranglar berilgan?

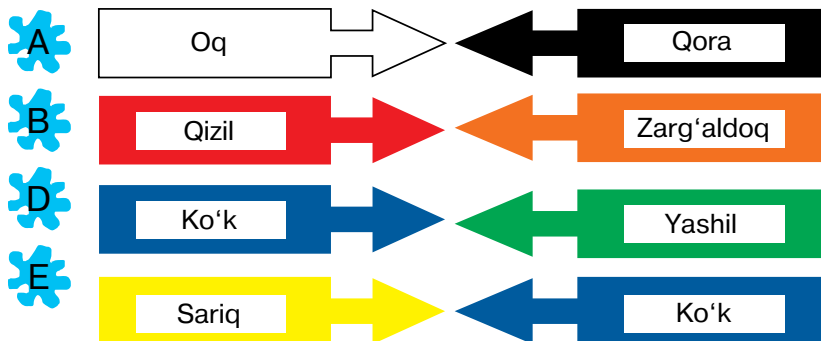

2. Qaysi naqshning ikki xil bezak guli bor?

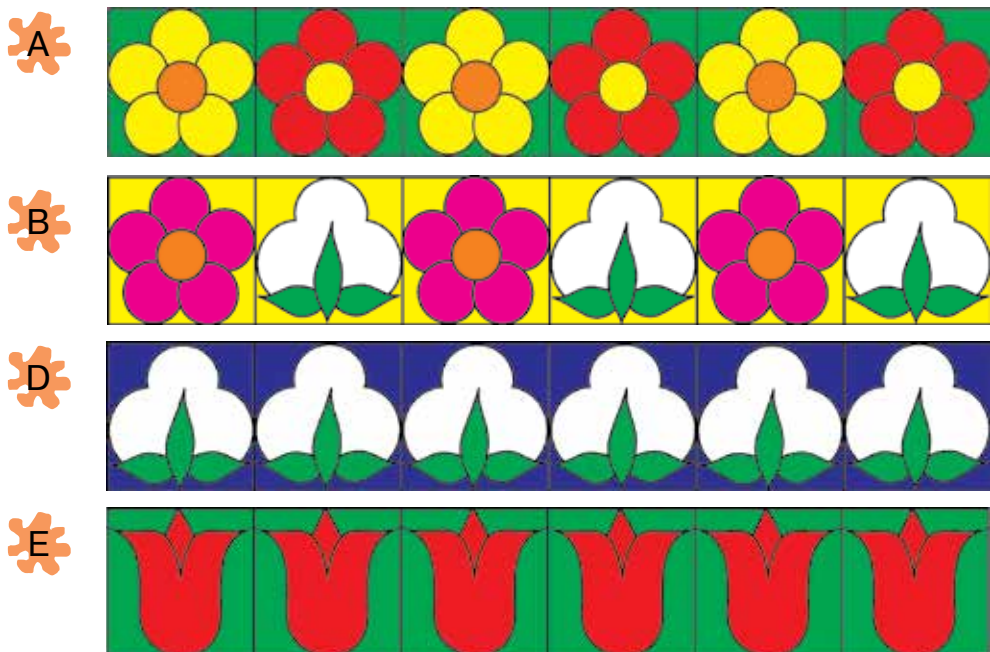

3. Qaysi ranglar juftligi kontrast emas?

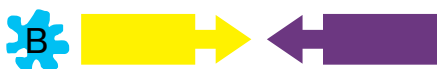

4. Qaysi naqshning foni va bezak gulining rangi to'g'ri tanlanmagan?

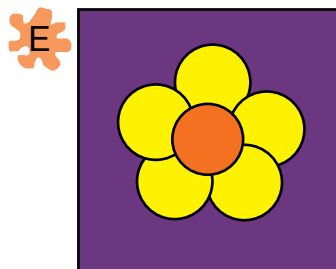
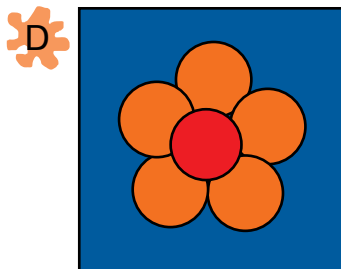
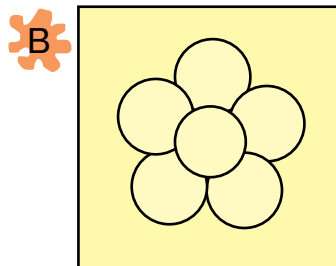
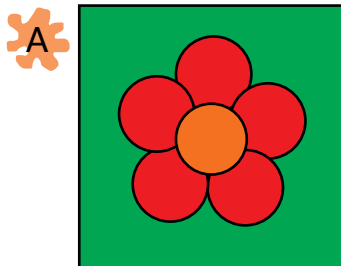

5. Qaysi rasmda relyefli haykal tasvirlangan?



## II. Topshiriq.

«Hosil bayrami» mavzusida hikoya tuzing va shu hikoya asosida rasm ishlang.

## II CHORAK



O. Qozoqov. *Chimyonda qish.*

### **Bu chorakda siz:**

- qish manzaralarini tasvirlashni;
- berilgan mazmun asosida haykal kompozitsiya ishlashni o'rganasiz;
- hikoya va ertaklar asosida illustratsiyalar ishlashni davom ettirasiz;
- applikatsiya ishlash bo'yicha bilim va malakalaringizni mustahkamlaysiz.





**Applikatsiya** deb tabiiy materiallar, rang-barang qog'oz va mato bo'laklarini qog'ozga yopishtirish orqali hosil qilingan tasvirga aytiladi.

Applikatsiyalardan kompozitsiyalar tuzish juda qiziqarli ish hisoblanadi. Uni rangli qog'ozlar, turli shakllar va rangli daraxt barglari, mato parchalaridan hosil qilish mumkin. Buning uchun barglarni rangi va shakliga ko'ra tayyorlab olinadi.

Quyidagi barglarning shakllarini diqqat bilan kuzat-sangiz, ular nimalargadir o'xshab ketishiga ishonch hosil qilasiz.

### Tabiiy materiallar:



1. Applikatsiyalar uchun to'kilgan meva urug'laridan, daraxt novdalari, shoxlaridan va barglardan foydalaniladi.



2. Ularning chang-g'ubori artib tozalanadi.
3. Barglar kitoblar orasiga qo'yib tekislanadi va quritib olinadi.
4. Bunday barglar o'ta sinuvchan bo'lganligi sababli, ulardan ehtiyotkorlik bilan foydalanish lozim.
5. Urug'lar sovuq suvda yuviladi va quritib olinadi.



### Applikatsiya yasash uchun zarur ashyolar.





## Kapalak rasmini applikatsiya usulida ishlash bosqichlari.

Kapalaklarda ikki juft qanotlar bo'ladi. Ular bir-biriga juda o'xshaydi. Tanasi ingichka va uzunchoq, mo'ylovlari juda nozik, ko'zlari esa mittigina bo'ladi.

1



Ikkita eng chiroyli bir xil barglar ustki qanotlar uchun tanlanadi.

2



Ostki qanotlar uchun kichikroq barglar tanlanadi.

3



Tanasi uchun ingichka uzun barg to'g'ri keladi.

4



Ko'zlar uchun ikkita bir xil urug' tanlanadi. Mo'ylov uchun barg bandlaridan foydalaniladi.

5

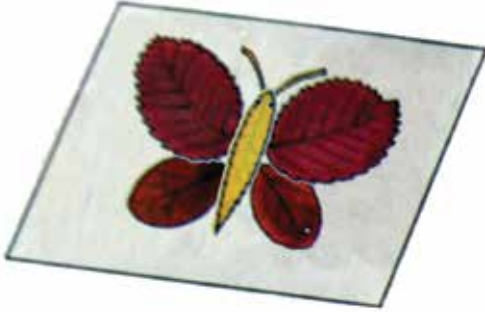

Barcha barglar asosga  
kapalak shaklida  
joylashtiriladi.

6



Har bir qism yelim bilan  
yopishtiriladi.



**Quyion tasviri applikatsiyasi quyidagicha ishlanadi.**

Quyionning quloqlari uzun, yonoqlari lo'ppi, oldingi oyoqlari orqa oyoqlaridan kaltaroq bo'ladi.



1



Quyoning quloqlari, boshi, yonoqlari, tanasi, oyoqlari uchun barglar tanlanadi. Burun va ko'zlari uchun urug'lardan foydalaniladi.

2



Barcha tana qismlarini asosga qo'yib olamiz.

3



Ularni bir-biriga yaqinlashtiramiz.

4



Barcha tana qismlari asosga yelim yordamida yopishtiriladi.

5

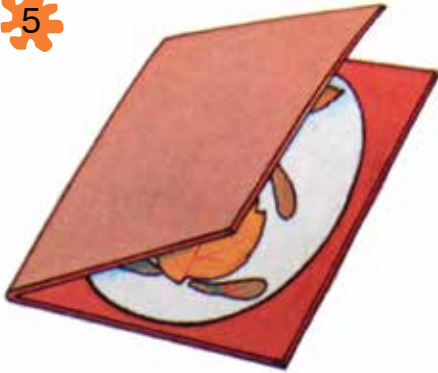

Tayyor bo'lgan applikasiya papkaga yoki kitob orasiga solinadi va ustidan kitoblar bostirib qo'yiladi.



1. Applikasiya nima?
2. Applikasiya yasash bosqichlarini ayting.



Berilgan applikasiyaga qarab, siz ham sher applikasiyasini ishlang. Kichikroq barglar bo'lmasa, katta barglardan kesib oling. Ko'zlari va burni uchun urug'lardan foydalaning.



1. Sinfda ishlangan sher applikasiyasini oxiriga yetkazing.
- 2\*. Istalgan ikki nafar jonivor applikasiyasini ishlang.

Oltin rangga burkangan kuz manzaralari har bir rassomni zavqlantiradi. Kuzgi ko‘rinishlarni o‘z asarlarida maroq bilan aks ettirgan rassomlar talaygina. Ular R. Ahmedov, G‘. Abdurahmonov, H. Karaxan, N. Qo‘ziboyev, Z. Inog‘omov va boshqalardir.



O. Qozoqov. *Qasrakda kuz.*



Yuqoridagi birinchi rasmda quyoshli, ochiq havodagi kuz manzarasi tasvirlangan.

Yuqoridagi rasmda tasvirlangan kuz manzarasini diqqat bilan kuzating va uning mazmunini gapirib bering.



Avvalo daraxt, togʻ, bulut kabilarning rasmi qanday ishlanishini bilib oling. Masalan, daraxt rasmlari quyidagicha bosqichlarda ishlanadi.

1



2



3



4



1



2



3



4



1



2

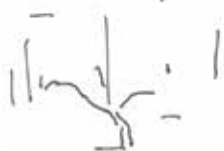

3



4



1

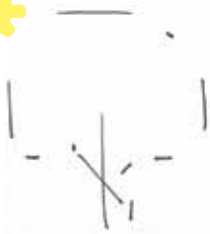

2



3



4





Endi siz ham yuqorida qayd qilingan rassomlar kabi chiroyli manzara rasmini ishlang. Bunda darslikda berilgan kuz rasmlari va o'zingiz ko'rgan manzaralarni xotirlab rasm ishlang.



**«Kech kuz manzarasi» rasmini ishlash bosqichlari.**

1

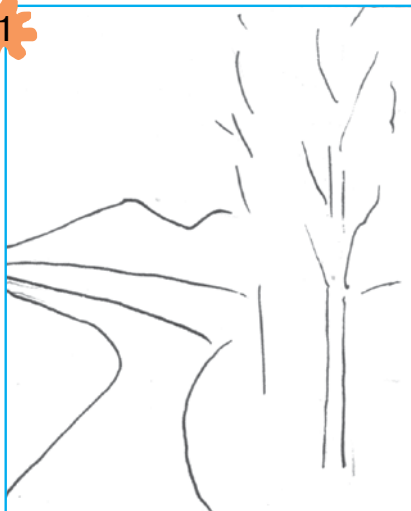

2

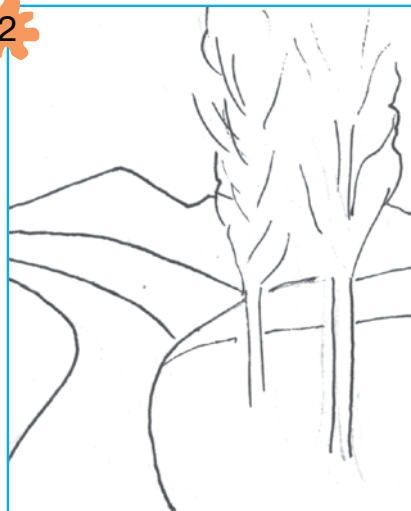

3



4





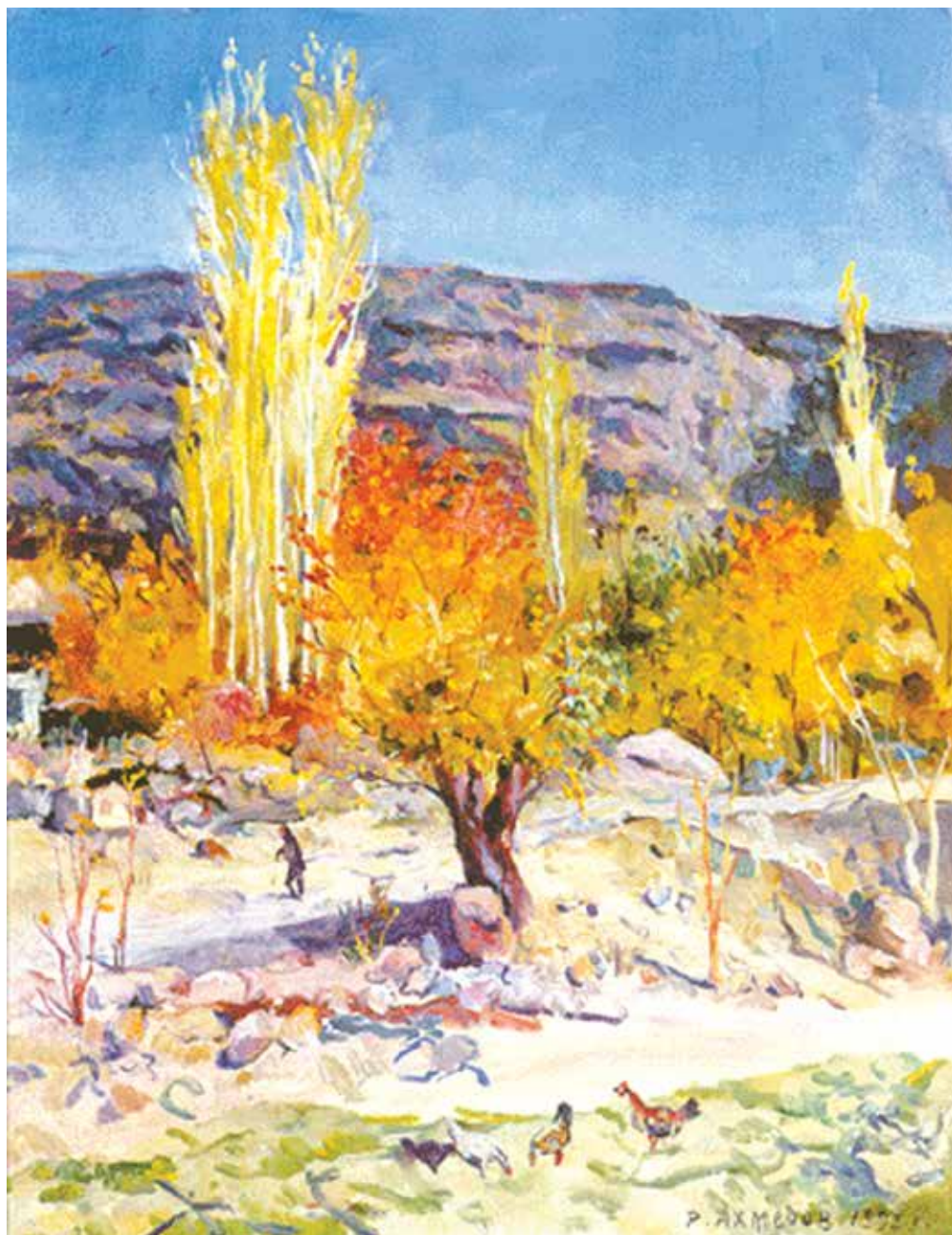

R. Ahmedov. *Kuz tabiati manzarasi.*



1. Sinfda chizilgan «Kuz manzarasi» rasmini guash yoki akvarelda bo'yang.
- 2\*. «Yomg'irli kun» mavzusida rasm ishlang.

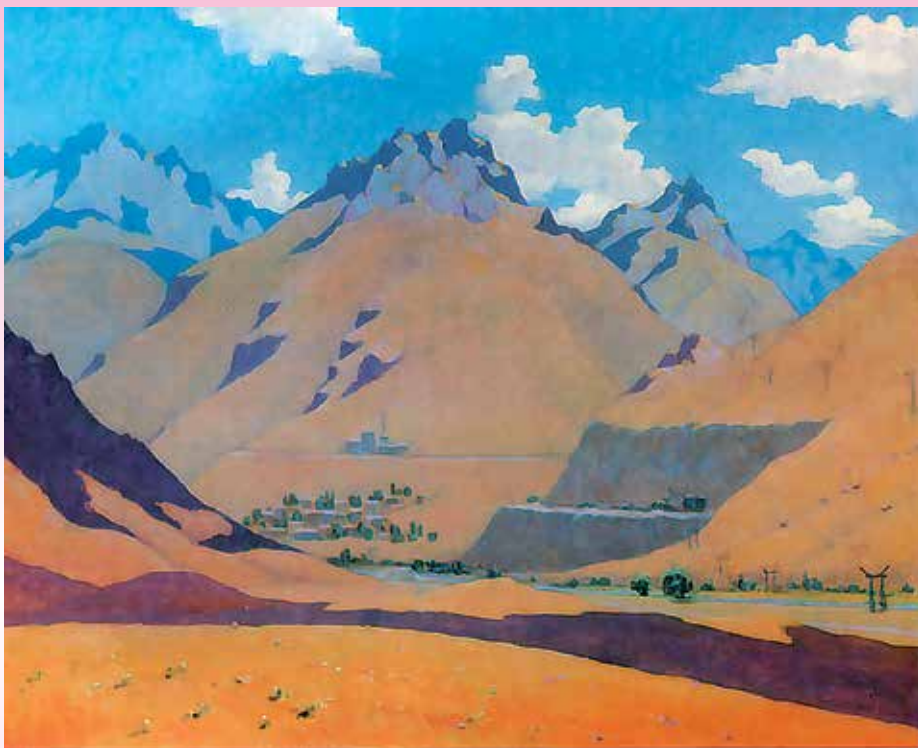

N.G.Karaxan. *Kuz.*

**Karaxan Nikolay Grigoryevich** (1900-1970) – O'zbekiston xalq rassomi. Asarlarida o'zbek xalqining hayoti va mehnat faoliyati hamda tabiat manzaralarini aks ettirgan. U manzara janridagi «Nanay yo'li», «Yashnayotgan vodi», «So'nggi nur», «Oltin kuz», «Kuz» va boshqa asarlari bilan mashhur.

**Toshbaqa bilan chayon**

Gulxaniyning «Toshbaqa bilan chayon»  
masalining qisqacha mazmuni

Toshbaqa bilan chayon safarga chiqdilar. Yo'lda ular katta daryoga duch keldilar. Toshbaqa suvdan chayonni olib o'tib yaxshilik qilmoqchi bo'ldi va chayonni ustiga mindirib oldi. Daryo o'rtasiga kelganda, chayon bejo harakat qila boshladi. Toshbaqa buning sababini so'raganida, u nayzasini toshbaqaga sanchib, sinab ko'rmoqchi ekanligini aytdi. «Chayonning ishi xoh do'st ko'ksiga va xoh dushman orqasiga nish urmoqdan iboratdir», — dedi. Toshbaqa esa: «Unda mening ham suv yuzida yurishimdan naf yo'q, mening ishim daryo



javohirlarini tomosha qilishdir», – deb daryo tubiga sho'ng'idi.

Shunday qilib, toshbaqa javohir termoqqa, chayon esa jon bermoqqa ketdi. Yaxshilikka – yomonlik, deb shuni aytadilar.

### Maqol

Yaxshiga yondash, yomondan qoch.



1. «Toshbaqa bilan chayon» masalini o'qib chiqing.
2. Rasmda masalning qaysi lavhasi tasvirlangan?

O'zbekistonlik rassomlar xalq ertaklari, masallar va boshqa adabiy asarlarga ko'plab illustratsiyalar ishlaganlar. Iskandar Ikromov, Telman Muhamedov, Abduqahhor Mahkamovlar shular jumlasidandir.



Endi siz masaldagi bironta ko'rinish yoki voqea-ning illustratsiyasini ishlang.



**Illustratsiya** — badiiy asar mazmunini to'ldiruvchi yoki ko'rgazmali tasvirlovchi rasm.



**Toshbaqa rasmi shunday bosqichlarda chiziladi.**

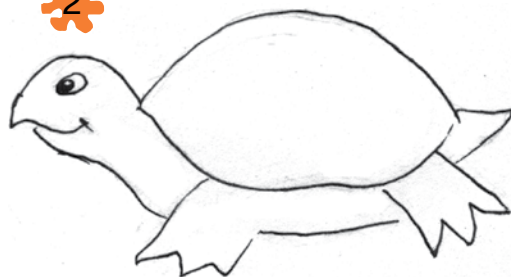

3

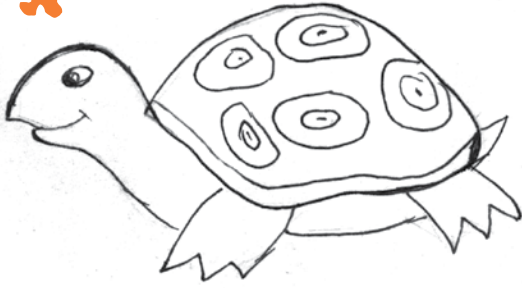

4



Chayon rasmi esa bunday chiziladi.

1



2



3

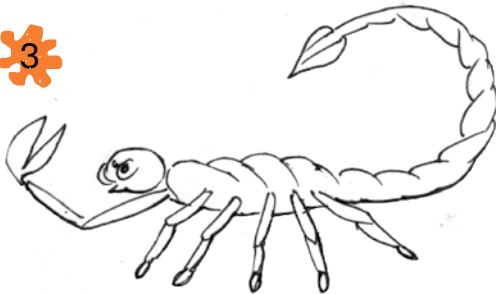

4





1. Illustratsiya nima?
2. O'qish kitobingizdagi turli xil asarlarga ishlangan illustratsiyalarni aniqlang va ularni tahlil qiling.



1. «Toshbaqa bilan chayon» masaliga ishlangan illustratsiyani akvarel bo'yoqlar bilan bo'yang.
- 2\*. O'zingiz sevgan birona ertakka illustratsiya ishlang.



Buyuk rassom Kamoliddin Behzod ham turli asarlarga illustratsiyalar ishlagan.



Kamoliddin Behzod  
(1455-1536)



K.Behzod.  
*Masjid  
qurilishi.*

Kamoliddin Behzod – Sharqning buyuk musavviri. U A. Navoiy, Bobur va boshqa shoirlarning asarlariga illustratsiyalar ishlagan. Behzod «Sulton Husayn saroyida ziyofat», «Doro va otboqarlar», «Masjiddagi bahs», «Olimlar suhbatlari» va boshqa asarlari bilan mashhur.





*Yakov Shapiro. Xo'ja Nasriddin haykali.*

O'zbek xalq og'zaki ijodida afsonaviy, xalqning sevimli va quvnoq qahramoni — Nasriddin Afandi obrazi muhim o'rin tutadi. U hayotda yashab o'tmagan bo'lsa-da, xalqimiz uning haqida son-sanoqsiz latifalarni to'qigani to'qigan. Nasriddin Afandi qiyofasi tasviriy san'atga shu latifalar orqali kirib kelgan.



Rasmdagi haykalga qarab Nasriddin Afandi haqida qanday tasavvur hosil qildingiz?



## Eshak haykalini yasash bosqichlari.

1



2

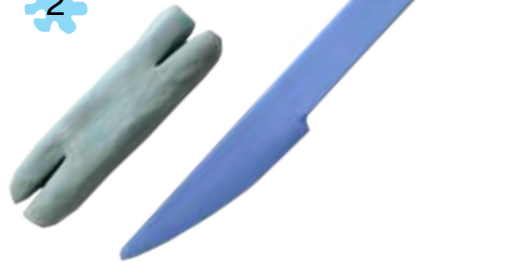

3



4



5



6







## Nasriddin Afandi haykalini yasash bosqichlari.

1



2

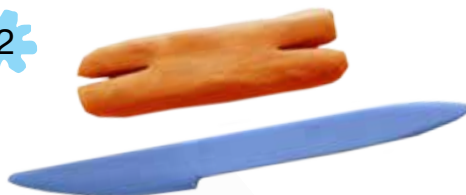

3



4



Nasriddin Afandi va uning eshagi ishtirokida-gi biror lavhani ko'z oldingizga keltiring. Lavha asosida haykaltaroshlik kompozitsiyasini tuzing va unga nom qo'ying.

### Afandi mergan

Afandi: «Merganman», – deb maqtanib yurar edi. Bir kuni podsho uni ovga olib chiqdi. Bir joyda o'tlab yurgan kiyik uchrab qoldi. Afandi darrov kamondan o'q uzgan edi, xato ketdi. Afandi xijolat bo'ldi va podshoga qarab:

– Bu sizning o'q otishingiz, – dedi.

Afandi yana o'q uzdi. U ham xato ketdi.

– Bu vaziringizning o'q otishi, – dedi.

Uchinchi marta o'q otgan edi, kiyikka tegdi.

– Mana bu mulla Nasriddinning o'q otishlari, – dedi Afandi.



## Nasriddin Afandi latifalari asosida ishlangan haykallar.



1. Yuqoridagi haykallarning mazmuni va tuzilishi haqida soʻzlab bering.
2. Haykaltaroshlik kompozitsiyasi nima?



1. Sinfda ishlangan haykaltaroshlik kompozitsiyasini oxiriga yetkazing.
- 2\*. Biror latifa mazmunidan kelib chiqib, sinfda ishlangan haykallardan foydalanib, yangi kompozitsiya tuzing.



15

«DORBOZ BOLA» MAVZUSIDA  
RASM ISHLASH



A. Temurov. Samarqand dorbozlari.



1. Yuqoridagi rasmda kimlar tasvirlangan?
2. Dor o'yinlarini tomosha qilganmisiz? Taassurotlaringizni so'zlab bering.

## Dorbozlik

Dorbozlik baland dor ustida tomosha ko'rsatish san'ati hisoblanadi. U qadim tarixga ega. O'zbek dorbozlari 25-30 metr balandlikdagi ustunlarga tortilgan arqon ustida langarcho'p bilan o'yin ko'rsatadilar. Dorbozlar yugurish, sakrash, oyoqlarga pichoq yoki patnis bog'lagan holda, shuningdek, ko'zni bog'lab, boshlariga xaltacha kiyib arqon ustida mashqlar bajaradilar. Dor o'yinlari, dor tagida raqqoslarning o'yinlari, qiziqchilar, askiyachilarning chiqishlari hamda an'anaviy sirk turlaridan simdor, yog'och oyoq, nayrangbozlik, besuyak, o'rgatilgan ayiq, ilon, maymun, ot o'yinlari bilan birga olib boriladi.

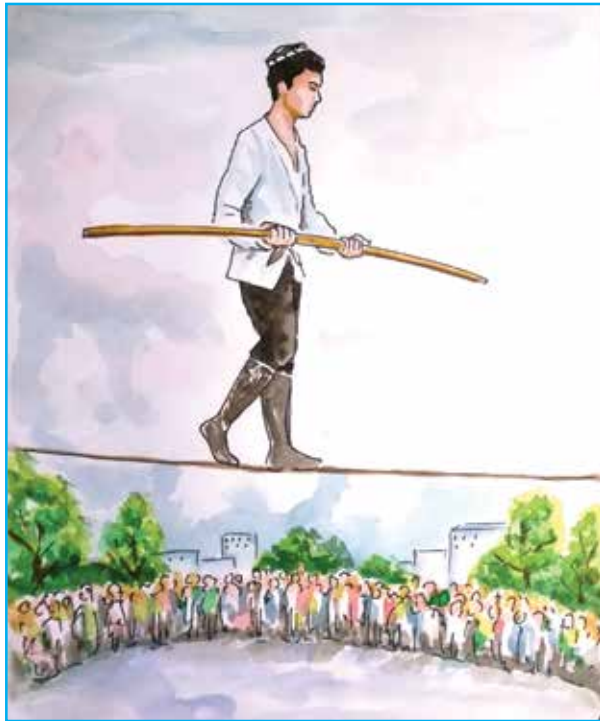



## Dorboz bola rasmini ishlash bosqichlari.

1

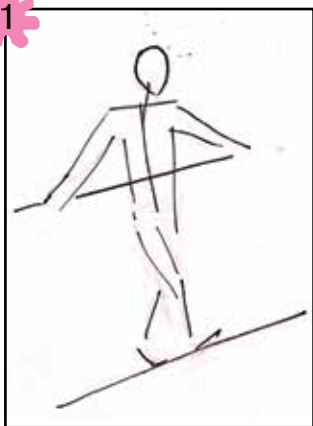

Tasvirni qog'ozga joylashtirish.

2



Qalamda xomaki ishlash.

3



Och ranglarda ishlash.

4



To'q ranglarda ishlov berish.



«Dorboz bola» mavzusida rasm ishleng.



1. Dorbozlik san'ati haqida yana nimalarni bilasiz?



1. Sinfda boshlangan «Dorboz bola» mavzusida rasm ishlashni oxiriga yetkazing.

2\*. «Dorboz bola» deb nomlangan haykallar kompozitsiyasini ishleng.



### O'lkamizda qish

Ertalabki quyosh o'zining kuchsiz, zarrin nurlarini sochmoqda. Hamma yoq oppoq qor. Daraxtlar oppoq to'n kiygan. Uylar mo'risidan tutun chiqmoqda. Esayotgan sovuq shamol tutunlarni uzoqlarga uchirib ketmoqda. Ayoq uy derazalariga g'aroyib naqshlar chizgan. Qor bosgan dalalarda qarg'alar qo'nim topgan. Osmon to'q zangori tusga kirgan.



R. Xudayberganov. *Qish manzarasi.*



1. Yuqoridagi rasm va o'z taassurotlaringiz asosida qish fasli haqida hikoya qilib bering.
2. Qish faslining eng asosiy xususiyatlarini ayting. Ular rasmda qanday ranglarda tasvirlangan?



«O'lkamizda qish» hikoyasi asosida rasm ishlang. Rasm chizishga kirishishdan avval nimalarni tasvirlash mumkinligi haqida o'ylab ko'ring: daraxtlarning yaproqsiz, qor bilan qoplangan mudroq holati, qor bosgan uylarning tomidagi mo'rilardan chiqayotgan tutun, shuningdek, qorli so'qmoqlar, dala, adir va tog'lar, qushlar siz ishlayotgan kompozitsiyaga element bo'lishi mumkin.



X. Ro'zmetov. *Qish.*

Rasm chizishga kirishishdan avval rassomlarning qish mavzusida ishlagan asarlarini diqqat bilan kuza-ting.





2



Z. Asqarov. *Xiva. Qishki manzara.*

3



O. Qozoqov.  
*Bolalik tandiri.*



72–73-betlardagi rasmlarning qaysi biri quyidagi she'r mazmuniga mos keladi?

Qish kechasi, guvillar shamol,  
Dalada qor, qush inida qor.  
Ingrar og'riq kabi qari tol,  
Oynalarni bezar qish — gulkor.



I. Bahromov. *Qishki kun.*



1. Sinfda ishlangan «O'lkamizda qish» mavzusidagi rasmni bo'yang.

2\*. Tasavvuringiz asosida «Qish» deb nomlangan rasm ishlang.



## I. Test savollari:

1. Quyida keltirilgan tasviriy va amaliy san'at asarlari turlarini aniqlang.

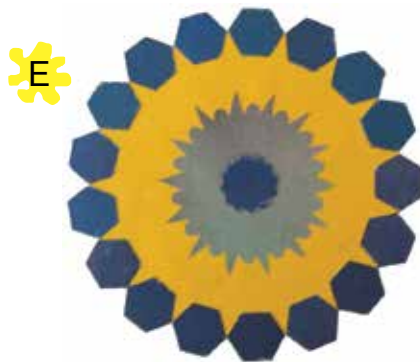

1. Applikatsiya;  
2. Haykaltaroshlik;  
3. Rangtasvir;  
4. Dekorativ kompozitsiya.
2. Qish manzarasini tasvirlashda asosan qanday ranglar ishlatiladi?

A Iliq ranglar;

D Asosiy ranglar;

B Sovuq ranglar;

E Kontrast ranglar.

3. Ushbu bezak guli qaysi to'rtburchak naqshga tegishli?

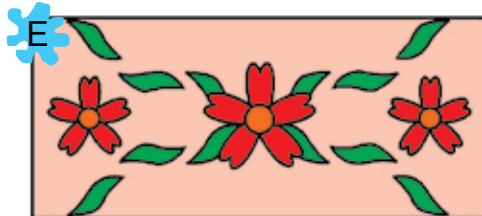
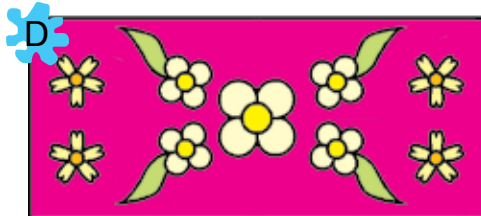
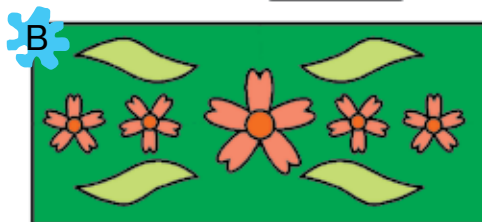

4. Keltirilgan rasm tasviriy san'atning qaysi janriga tegishli?



A Haykaltaroshlik

B Grafika

D Rangtasvir

## II. Topshiriq.

«Qor yog'yapti» mavzusida rasm ishlang.



## III CHORAK



G'. Abdurahmonov. *Bahor.*

### **Bu chorakda siz:**

- qish faslidagi bolalar o'yinlarining o'ziga xos xususiyatlarini tasvirlashni;
- bahor manzarasi va Navro'z bayramini tasvirlashni;
- multfilm qahramonlarini tasvirlashni;
- murakkabroq natyurmort chizishni o'rganasiz.



Qish fasli bolalar uchun zavqli lahzalarga boy bo‘ladi. Sovuq iqlim tufayli hosil bo‘lgan yaxmalaklar, qorli yerlar bolalar uchun qiziqarli o‘yin maydoniga aylanadi. Ular chang‘i, konki uchadilar, qorbo‘ron o‘ynaydilar va qordan qorbobo haykalini yasaydilar. Quyidagi rasmda rassom shunday lahzani tasvirlagan:



1. Bolalar qishki ta'tilda qanday o'yinlar o'ynaydilar?
2. Qish faslini tasvirlashda ko'proq qaysi ranglar ishlatilgan?



## Qorbobo rasmini ishlash bosqichlari.

1

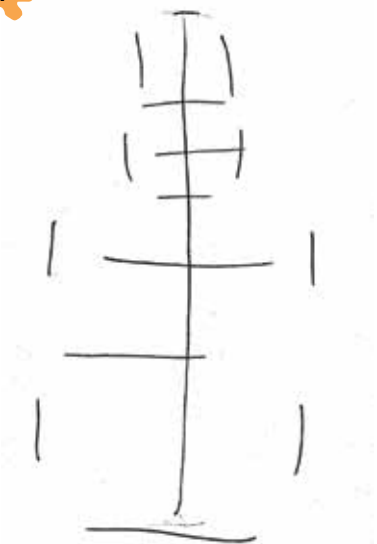

2



3



4





Ko'rgan rasmlaringizdan foydalanib yangicha ko'rinishda «Qishki o'yinlar» deb nomlangan rasm islang.

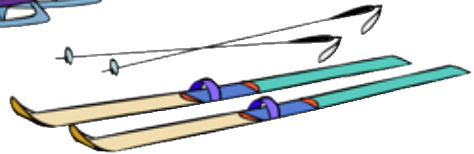





1. «Qishki o‘yinlar» mavzusidagi rasmni ishlashda qanday ranglardan foydalaniladi?



1. «Qishki o‘yinlar» mavzusida rasm ishlashni oxiriga yetkazing.

2\*. «Chana uchish» mavzusida rasm ishlang.



**Tengdoshingiz ijodidan.** *Qish manzarasi.*

Ona yurtimiz qadimiy me'moriy obidalari bilan mashhur. Ularni bu qadar mo'jizakor bo'lishida naqshinkor bezaklarning o'rni beqiyos! Ularni yaratishda naqqoshlar bilan birga koshinkorlar ham ishtirok etganlar. Me'morchilikdagi naqshlar koshin parchalarini birlashtirish usuli bilan hosil qilinadi.



*Bibixonim masjidi.*



*Imom al-Buxoriy maqbarasi.*



*Sherdor madrasasi.*



1. Rasmlarda tasvirlangan me'moriy yodgorliklar haqida nimalarni bilasiz?
2. Ularga badiiy bezak berishda qanday naqshlardan foydalanilgan?



**Me'morlik** — bino va inshootlarni loyihalash va qurish san'ati.

Me'morlik asarlari qatoriga turli-tuman binolar, uyjoylar, me'moriy majmualar, maydonlar, shaharlar, ulardagi monumentlar kiradi.

### **Zamonaviy me'morlik san'ati namunalari.**



*Temuriylar tarixi davlat muzeyi.*



*Toshkent Islom universitetining binosi.*



Ushbu qadimiy me'moriy yodgorlik namularidagi biror naqshdan nusxa oling.



1. Yurtimizda qanday me'moriy obidalar bor? Ular haqida so'zlab bering.
2. Qadimda me'morlar ko'proq naqqoshlikning qaysi turlaridan foydalanganlar?



1. Sinfda ishlangan qadimiy naqsh nusxasini ishlashni oxiriga yetkazing va uni bo'yang.
- 2\*. Yurtimizdagi biror qadimiy obida rasmini ishlang.



Temuriylar tarixi davlat muzeyi binosining gumbaz osti shiftiga ishlangan naqsh

**Ilhomov Anvar** (1946-yilda tug'ilgan) — naqqosh, O'zbekistonda xizmat ko'rsatgan san'at arbobi. U «Istiqlol», «Turkiston» saroylari, Temuriylar tarixi davlat muzeyi, Imom Buxoriy, Ahmad Farg'oniy majmualarini bezashda ishtirok etgan.





Hayvonot bog'ida bizga tanish hayvonlar bilan bir qatorda o'lkamizda uchramaydigan noyob hayvonlar ham bor.

Toshkent hayvonot bog'ida fil, yo'lbars, sher, ayiq, bo'ri, kenguru, maymun, zebra kabi hayvonlarni, har xil qushlar va suv jonivorlarini uchratish mumkin.



1. Rasmlarda qaysi hayvonlar tasvirlangan?
2. Ularning qaysilari mamlakatimiz hududida uchraydi?
3. Ularning o'lchamlari va ranglari haqida nimalarni bilasiz?



## Fil rasmini ishlash bosqichlari.

Hayvon rasmini ishlayotganingizda uning tanasi qanday qismlardan tuzilganligini va bu qismlar qanday shaklga ega ekanligini aniqlash lozim.

Masalan, filning tanasini, to'rtta oyoq, kal-la, xartum, dum, tishlari va quloqlarini alohida ajratib ko'rsatish mumkin.

Filning eng katta qismi — bu uning tanasi bo'lib, u oval shaklda. Uning boshi va quloqlari deyarli bir xil kattalikda bo'lib, ular ham oval shaklda.

1



2

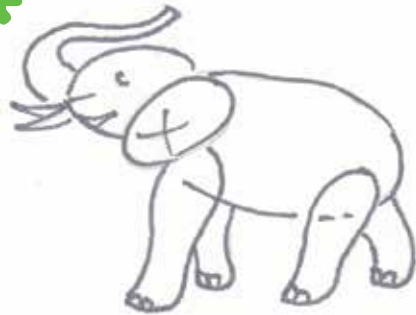

3

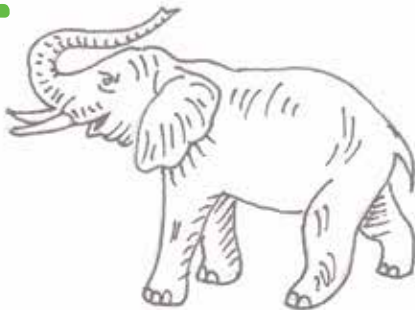

4

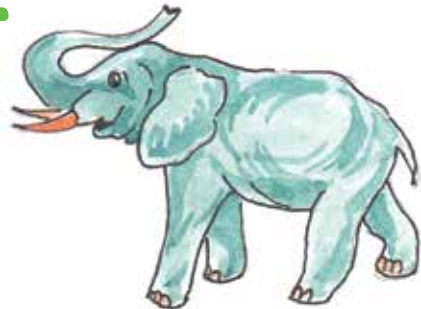

Hayvonot bog'idagi ayrim hayvonlar tuzilishiga ko'ra o'xshab ketadi. Masalan, zebra otga o'xshaydi.



A. Aliqulov. Yorug'likka.



### Ot rasmini ishlash bosqichlari.

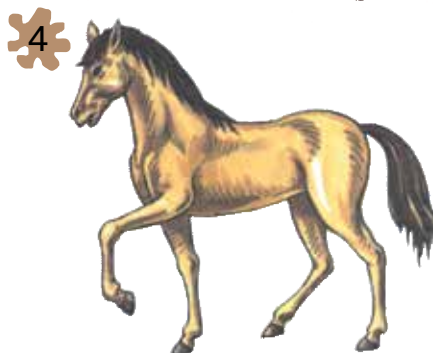
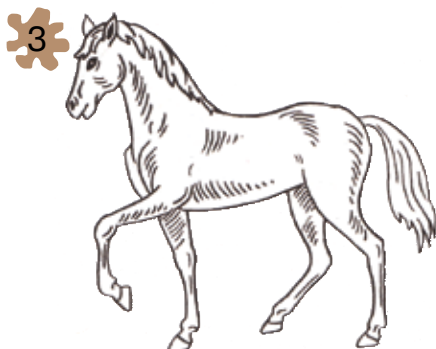
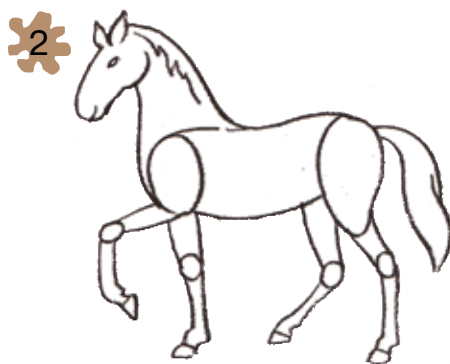





## Baliq rasmini ishlash bosqichlari.

1



2

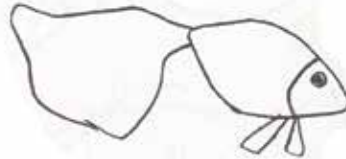

3

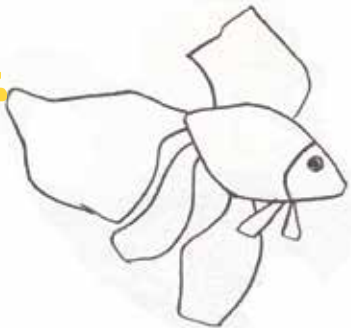

4





## Quyov rasmini ishlash bosqichlari.

1



2



3



4



«Hayvonot bog'ida» mavzusida rasm ishleng. Bu jarayonda yuqoridagi rasmlardan hamda tasavvuringizdagi variantlardan foydalanishga harakat qiling.



1. Sinfda ishlangan «Hayvonot bog'ida» mavzusidagi rasmni oxiriga yetkazing.

2\*. «Hayvonot bog'ida» mavzusida boshqa hayvonlar ishtirokida kompozitsiya ishleng.



21

## «OLTIN TARVUZ» ERTAGI ASOSIDA RASM ISHLASH

1

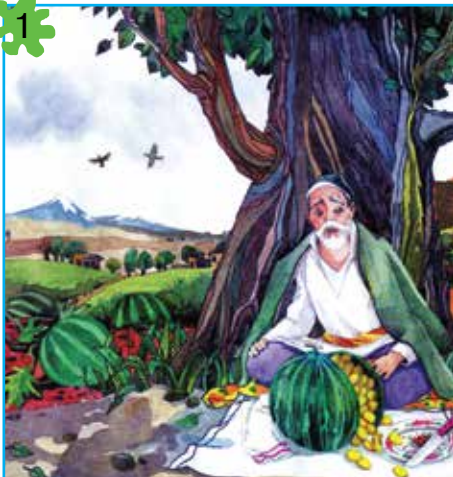

2

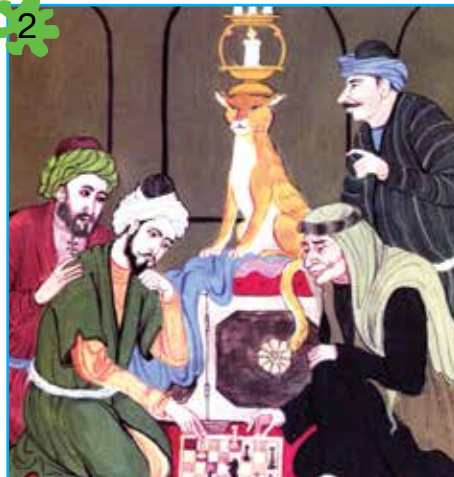

3

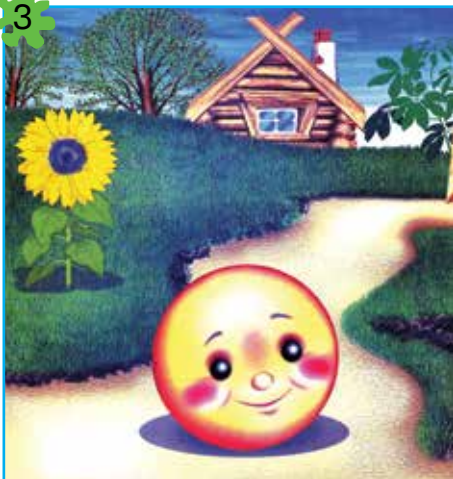

4



1. Yuqoridagi rasmlarda qaysi ertak qahramonlari tasvirlangan?
2. O'zingiz yoqtirgan ertak mazmunini so'zlab bering.

## Oltin tarvuz

Bir bor ekan, bir yo'q ekan, o'tgan zamonda bir kambag'al dehqon bo'lgan ekan. Dehqon yer haydayotganida osmonda uchib kelayotgan laylak yiqilib tushibdi. Dehqon laylakni o'z uyiga olib borib, siniq qanotiga taxtakach bog'lab, bir qancha vaqt uni parvarishlabdi. Laylak sog'ayib, uchib ketibdi.

Bir kuni dehqon chigit ekib yursa, laylak pastlab uchib kelib, uch dona tarvuz urug'i tashlab ketibdi. Ma'lum vaqt o'tgach chigit bilan birga tarvuz ham unib chiqibdi...



1. Ertakni davom ettiring.
2. «Oltin tarvuz» mavzusida rasm ishlang.





## «Oltin tarvuz» mavzusida rasm ishlash bosqichlari.



Tasvirni qog'ozga joylashtirish.



Qalamda xomaki ishlash.

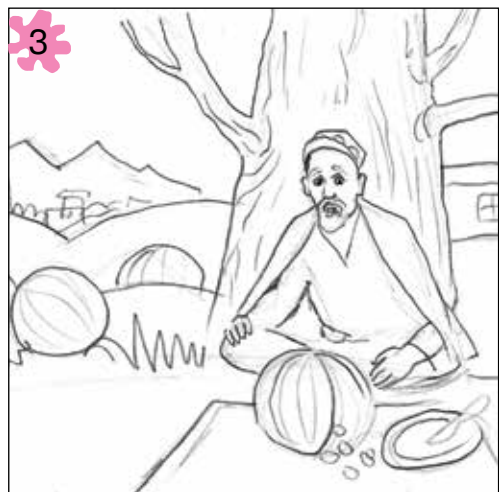

Tasvirni qalamda yakunlash.

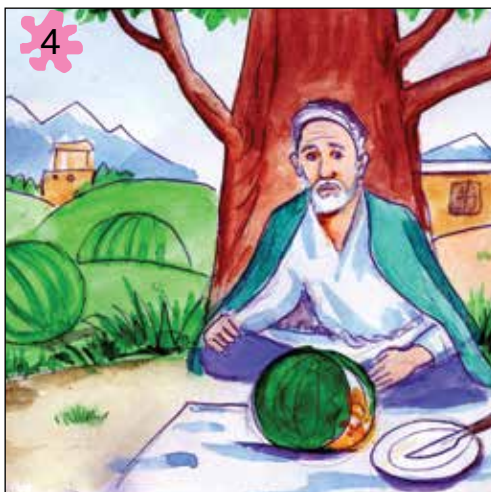

Tasvirni bo'yash.

Ertak qahramonlarini tasvirlashda ularning yuz ifodalari muhim ahamiyatga ega.



## Odamlarning turli xil yuz ifodalarini tasvirlash.

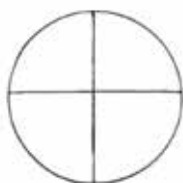

«Oltin tarvuz» ertagi asosida rasm ishlang.



1. Ijobiy va salbiy fe'l-atvorli ertak qahramonlariga misol keltiring.
2. Salbiy fe'l-atvorli qahramon qanday tasvirlanadi?



1. Sinfda ishlangan «Oltin tarvuz» mavzusidagi rasmni bo'yang.

- 2\*. Biror ertakka illustratsiya ishlang.



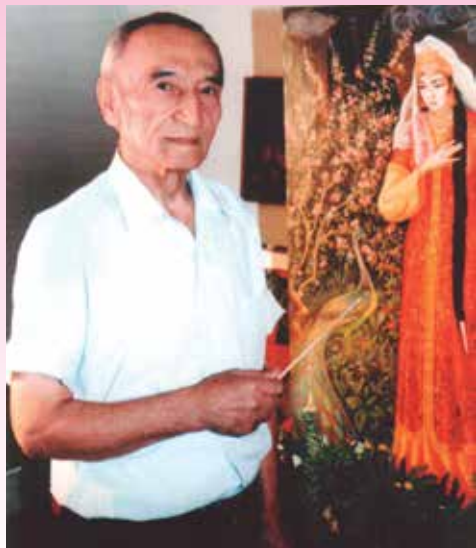

Qutlug' Basharov  
(1925—2004)



«Nodirabegim».

**Qutlug' Basharov** — O'zbekiston xalq rassomi, O'zbekiston Badiiy akademiyasining akademigi, professor. U portret, manzara, natyurmort, miniatura va tarixiy janrlarda ijod qilgan. Mashhur asarlari «Spitamen», «Alpomish», «Jaloliddin Manguberdi», «Ibn Sino», «Amir Temur» va boshqalar.



Yuqoridagi natyurmortni kuzating va quyidagi savollarga javob bering:



1. Nega bu rasm natyurmort deb nomlanadi?
2. Natyurmortda nimalar tasvirlangan?
3. Nima sababdan bu natyurmort tik holatdagi qo'g'ozda emas, balki yotiq holatda tasvirlangan?
4. Tasvirlangan uchta narsadan qaysi birining:
  - a) bo'yi eniga nisbatan uzun?
  - b) bo'yi eniga nisbatan qisqa?
  - d) bo'yi va eni taxminan teng?
5. Bu narsalarning qaysi biri dumaloq shaklda?



6. Qaysi narsa oldinda? Qaysi biri orqada turibdi? Buni nimalardan bildingiz?
7. Narsalarga yorug'lik nuri qaysi tomondan tushyapti? Buni qanday aniqladingiz?
8. Narsalarni tasvirlashda qaysi ranglardan foydalanilgan?
9. Har bir narsaning yorug' va soya joylarini aniqlang. Ularni tasvirlashda ranglardan qanday foydalanilgan?
10. Narsalar nimaning ustida turibdi? Ularning orqasida nima turibdi va u qanday tasvirlangan?



### **Naturmort ishlash bosqichlari.**

Dastlab, naturadan chizish talab etilgan narsalar diqqat bilan kuzatiladi. Kuzatish davomida yuqorida keltirilgan 10 ta savolga javob topiladi va shundan so'ng rasm ishlashga kirishiladi.

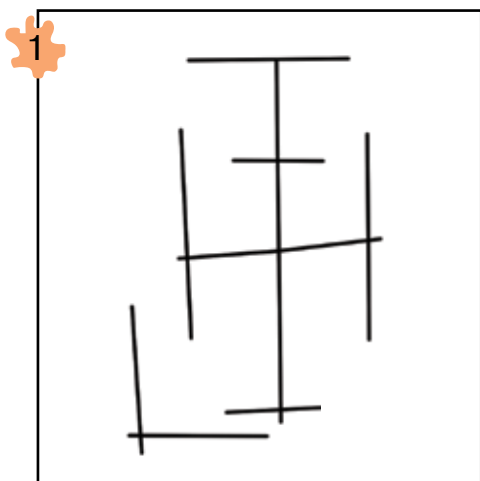

Tasvirni qog'ozga joylashtirish.

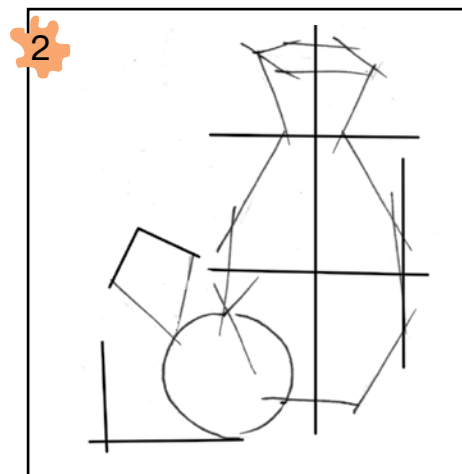

Qalamda xomaki ishlash.

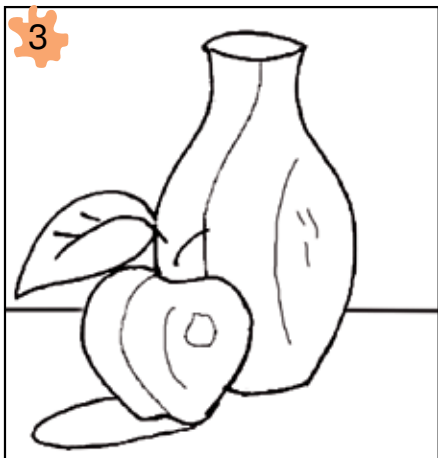

Tasvirni qalamda yakunlash.

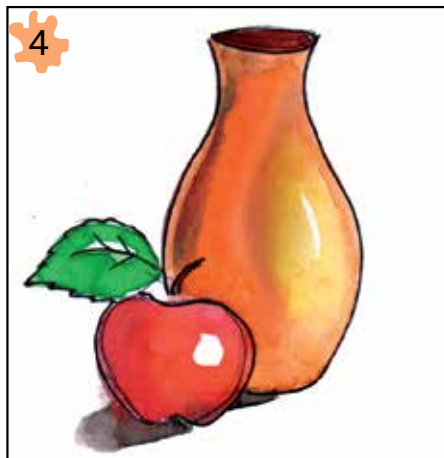

Bo'yash (bo'yash, oldingi darslarda berilgandek, 3-bosqichda amalga oshiriladi).



Stol ustiga joylashtirilgan olma va ko'zadan iborat natyurmortni ishlang. Natyurmort ishlashda undagi olma va ko'zaning shakli, o'zaro nisbatlariga e'tibor qarating. Rasmni qog'oz yuzasida to'g'ri joylashtiring.



1. Ko'zaning balandligi olma balandligidan qancha katta?
2. Ko'zaning eni olma enidan qancha katta?
3. Natyurmortga yorug'lik qaysi tomondan tushyapti?
4. Natyurmortda qanday ranglar bor?



1. «Olma va ko'za» natyurmortini ishlashni oxiriga yetkazing.
- 2\*. O'zingizga yoqqan 2–3 ta narsani qulay holda joylashtirib natyurmort ishlang.





«Tulki va turna» ertagidan parcha

Bir kuni turna tulkini ziyofatga chaqiribdi. Tulki tur-nanikiga kelibdi. Turna suyuq ovqat qilibdi, ko'zaga quyib o'rtaga qo'yibdi:

— Qani, Tulkivoy, oling, — deb tulkini ovqatga taklif qilibdi.



1. Ertakning to'liq mazmunini aytib bering.
2. Yuqoridagi rasmda qanday voqea tasvirlangan?
3. Nima uchun turna va tulki bir-biriga qo'ygan ovqatlarini yeya olmaydilar?



## Tulki haykalini ishlash bosqichlari

1



2

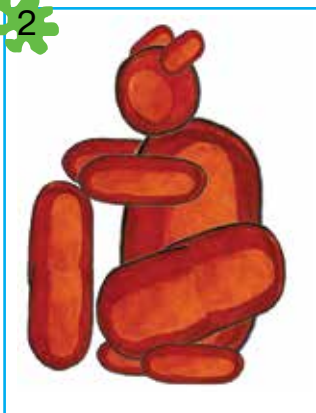

3



## Turna haykalini ishlash bosqichlari

1

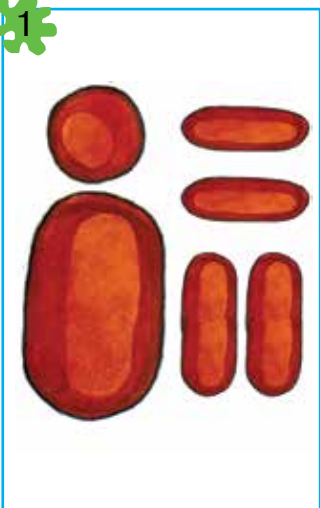

2



3



Yuqoridagi rasmlarda ko'rsatilgan tartibda «Tulki va turna» ertagi asosida haykalchalar ishlang. Ishlagan haykalchalaringsizni haykaltaroshlik kompozitsiyasi ko'inishida joylashtiring.



1. Yuqoridagi kompozitsiyada nimalar tasvirlangan?
2. Haykaltaroshlik kompozitsiyasi nima?



1. Tulki va turna haykallarini turli holatlarda joylashtirib, ertakdagi har xil vaziyatlarni tasvirlang va ularni nomlang.
- 2\*. «Tulki bilan turna» ertagi asosida



**O'zbekistonda sport**

O'zbekistonda sportga katta e'tibor qaratilgan. Sportning maqsadi kishilarning sog'lig'ini mustahkamlash va umumiy jismoniy rivojlantirish hisoblanadi. Tennis mamlakatimizda ommalashgan sport turlaridan biri bo'lib, unga qiziqish yildan yilga ortib bormoqda.



O'zbekistonlik sportchilar orasida tennischilarning o'z o'rnini bor. Denis Istomin, Farrux Do'stov, Iroda To'laganova, Nigina Abduraimova, Vlada Yaxshibarova kabi tennischilarimiz xalqaro arenalarda O'zbekiston sharafigini munosib himoya qilib kelmoqdalar.



1. Tennis sporti haqida nimalar bilasiz?
2. Siz qaysi sport turi bilan shug'ullanasiz?
3. Sport turlaridan qaysilari sizga yoqadi va nima uchun?
4. Endi tennis o'yinidan bironta ko'rinishni tanlang va shu asosida rasm ishleng.



**Masalan, tennischi rasmini ishlamoqchi bo'lsangiz, u quydagi bosqichlarda chiziladi.**

1



2



3



4



5



6



Yuqoridagi rasmdan foydalanib, tennis o'yini haqida kompozitsiya ishlang.



1. Mamlakatimiz sharafini xalqaro tennis musobaqalarida munosib himoya qilgan qaysi sportchilarni bilasiz?



1. Sinfda ishlangan tennischi rasmini bo'yang.  
2\*. O'zingiz yoqtirgan birona sport musobaqasi rasmini ishlang.





25

«BAHOR GULLARI»  
MAVZUSIDA RASM ISHLASH



Bahor kelishi bilan tabiat uygʻonadi. Dala va daraxtlar yam-yashil rangga kiradi. Gullar ochilib, borliq turfa ranglarga burkanadi.



O. Qozoqov. *Vodiyda bahor.*



1. Bahorda olma, oʻrik, gilos kabi mevalar qanday rangda gullaydi?
2. Rasmlarda bahor qanday ranglarda tasvirlangan?



## Atirgul rasmini ishlash bosqichlari.

1

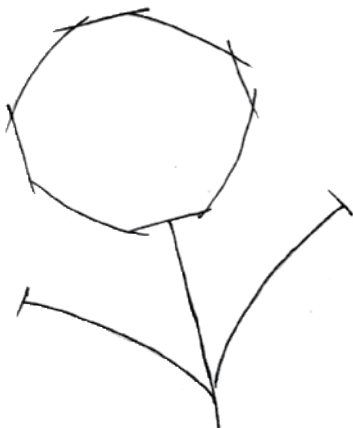

Tasvirni o'lchamlarini belgilash.

2

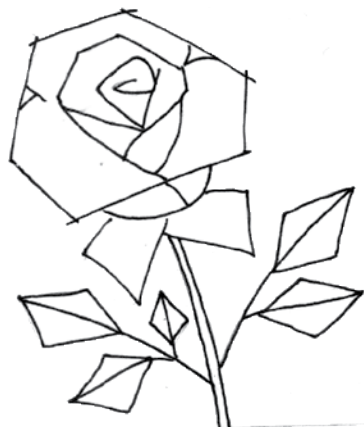

Qalamda xomaki ishlash.

3



Tasvirni qalamda yakunlash.

4

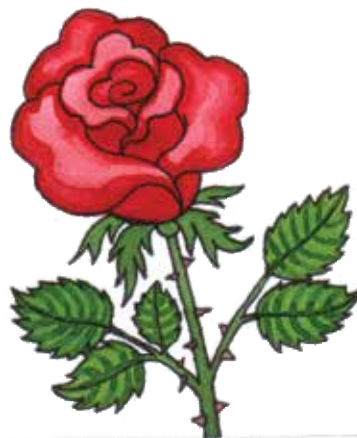

Bo'yoqlar bilan ishlov berish.



## Gullayotgan olma shoxi rasmini ishlash bosqichlari.

1



Tasvirni o'lchamlarini belgilash.

2

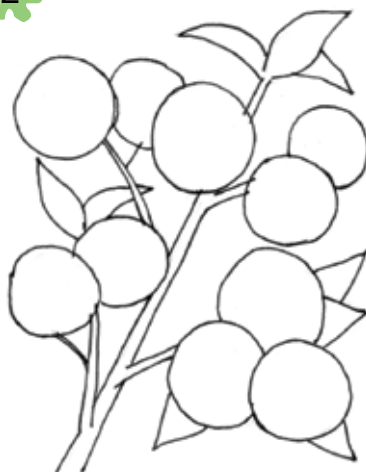

Qalamda xomaki ishlash.

3



Tasvirni qalamda yakunlash.

4



Bo'yoqlar bilan ishlov berish.



H. Mirahmedov. *Nastarin*.



## 8 ta farqni toping





«Bahor gullari» mavzusida rasm ishlang.



1. Bahor faslining ilk darakchilari deganda ko'z oldingizga nimalar keladi?
2. Rassom U. Ahmetjonovaning «Bahor» asari bo'yicha hikoya tuzing.



U. Ahmetjonova. *Bahor.*



1. «Bahor gullari» mavzusida chizilgan rasmni akvarelda bo'yang.

- 2\*. «Tog'larning bahorgi ko'rinishi» mavzusida rasm ishlang.





1. Rasmga nom qo‘ying va u bo‘yicha hikoya tuzing.
2. Navro‘zni nima sababdan bayram qilamiz?

Navro'z kuni bir-biridan xabar olish va bir-birini tabriklash xalqimizga xos fazilat. Bayram arafasida ko'chalarda katta qilib ishlangan tabriknomalarni uch-ratish mumkin.



Shuningdek, quyidagi tabrik so'zlari bitilgan tabriknomalarni yaqinlaringizdan olishingiz yoki ularga berishingiz mumkin:





Namuna asosida «Navro‘zingiz muborak bo‘lsin!» tabriknomasining rasmini chizing.



1. Navro‘z bayrami ramzlari sifatida nimalarni olish mumkin?



1. «Navro‘zingiz muborak bo‘lsin!» tabriknomasini akvarelda bo‘yang.

2\*. «Navro‘z» deb nomlangan dekorativ kompozitsiya ishlang.





## I. Test savollari:

1. Binafsha rangni ko'rsating.



2. Qaysi rasm sovuq ranglarda ishlangan?

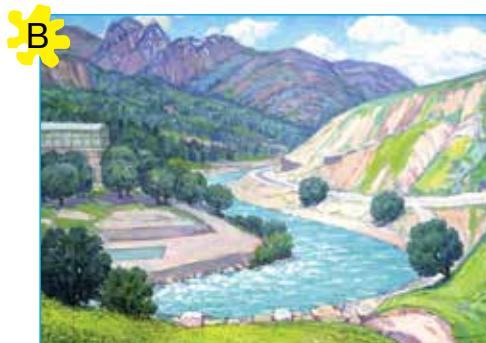

### 3. Kim qaysi rasmni ishlagan?

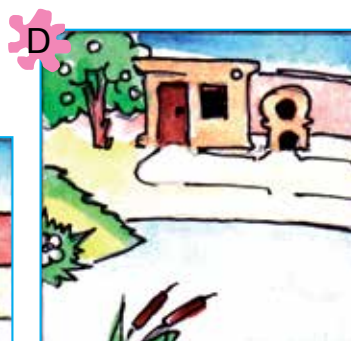
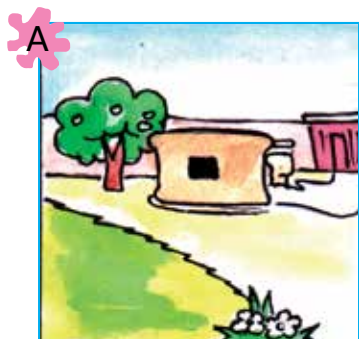
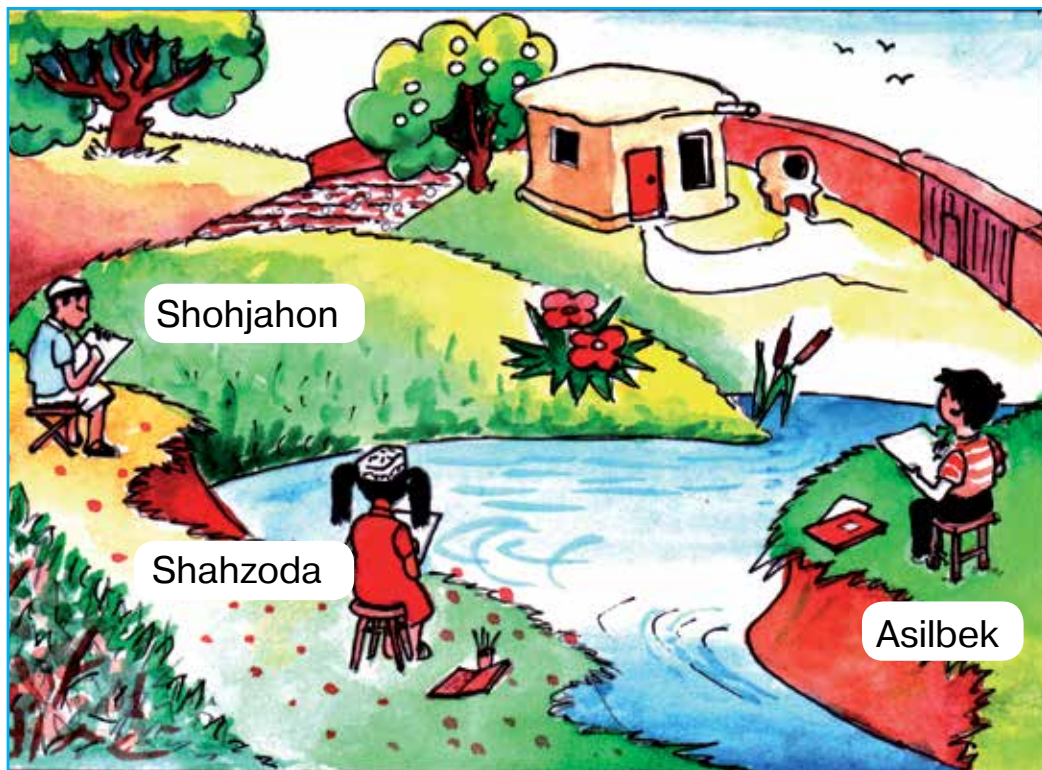

4. Quyidagi rasm tasviriy san'atning qaysi turiga tegishli?



*M. Toshmurodov. Munavvar.*

A Rangtasvir

D Naqqoshlik

B Haykaltaroshlik

E Grafika.

5. Rang nomining qaysi rasimga tegishli ekanligini aniqlang.



A Kulrang.

B Binafsha.

D Qizil.

E Zarg'aldoq.

## II. Topshiriq.

«Navro'zingiz muborak bo'lsin!» tabriknomasining taqdimotida ishtirok etib, chizgan rasmingizni unga qo'ying.



## IV CHORAK

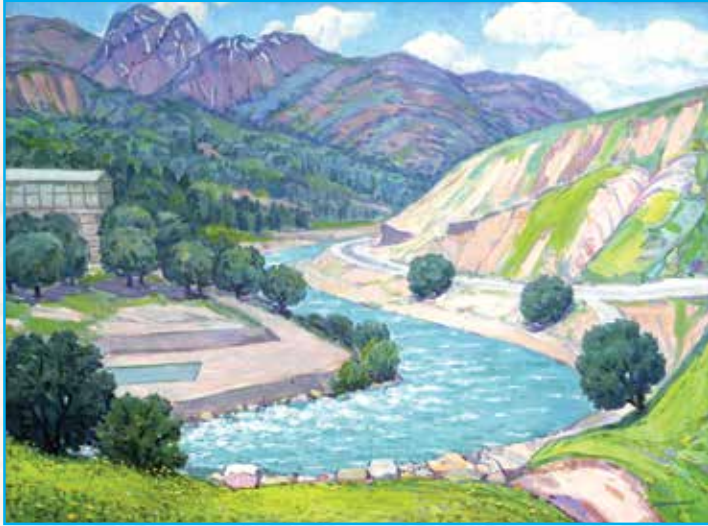

*G'. Abdurahmonov*

### **Bu chorakda siz:**

- tabiat manzarasi rasmini ishlashni davom ettirasiz;
- doiraviy shaklda naqsh ishlashni o'rganasiz;
- qadimiy hunarmandchilik turlaridan – kulolchilik namunalari bilan tanishasiz;
- haykaltaroshlik bo'yicha kompozitsiya ishlashni davom ettirasiz.





1. Yuqoridagi buyumlarda tasvirlangan doira shaklidagi naqshlarni ishlashda qanday bezak gullaridan foydalanilgan?
2. Doira shaklidagi naqshlarda simmetriya bormi? Ularni ko'rsating.
3. Kvadrat shaklidagi buyumda qanday bezak gullaridan foydalanilganligini aniqlang.

Naqsh ishlashga kirishishdan avval naqsh kompozitsiyasi, bezak gullarini aniqlab oling. Rasm qog'oz yuzasining qayerida, qanday o'lchamda tasvirlanishini belgilang.



## Doiraviy naqshlarni ishlash bosqichlari.

1

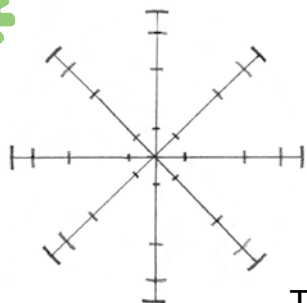

2

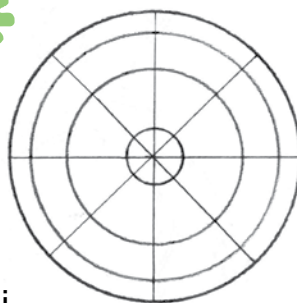

Tarh olinadi.

3

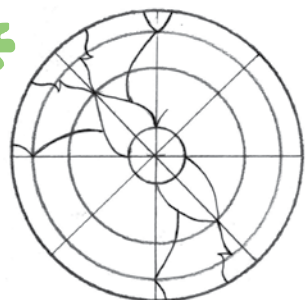

4

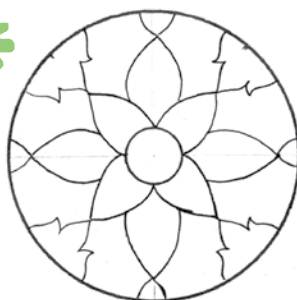

Bezak gullari chiziladi.

5



6



Bo'yaladi.





Berilgan tarh va bezak gullari bo'yicha doiraviy naqsh ishlang.

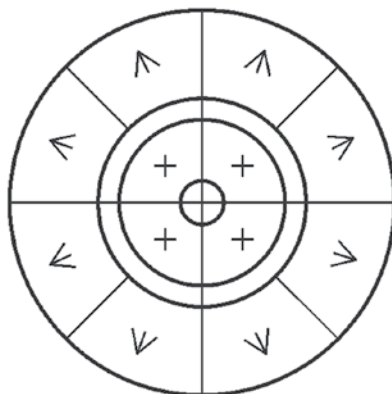
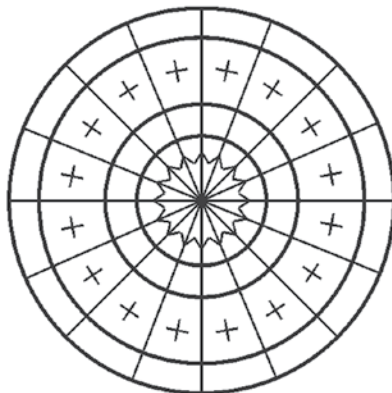
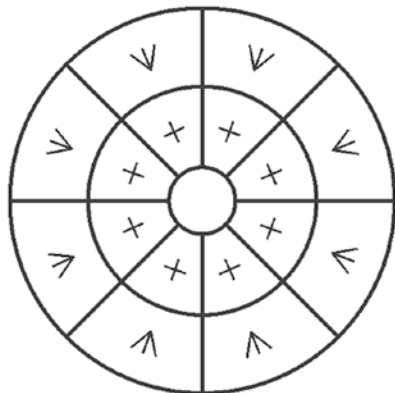

1. Doiraviy naqsh ishlash bosqichlarini aytib bering.
2. Doiraviy naqshda kontrast ranglarning ishlatilishini tushuntiring.



1. Sinfda boshlangan doiraviy naqsh ishlashni nihoyasiga yetkazing.
- 2\* . Gulsiz taqsimchaga guashda yoki akvarelda doiraviy naqsh ishlang.



29-30

## KULOLCHILIK. LOYDAN LAGAN YASASH



Kulolchilik hunarmandchilikning loydan piyola, kosa, ko'za, lagan, xum, o'yinchoqlar kabi turli buyumlar tayyorlaydigan turidir. Kulolchilikda asosiy qurol kulollik charxi hisoblanadi. Buyumlar qurilib, xumdonda pishiriladi. Kulolchilik respublika-mizning Farg'ona, Buxoro, Samarqand, Xorazm va Toshkent viloyatlarida keng rivojlangan. Xalq ustalari ko'plab idishlar tayyorlash bilan birga ularni yuksak did bilan bezaydilar. Kulolchilik buyumlari pishiq, chiroyli, nafis siri, ko'rkam naqshlari bilan diqqatni tortadi. Bu san'at turi avloddan avlodga o'tib kelmoqda.



*Kulollar ishlagan mahsulotlar.*



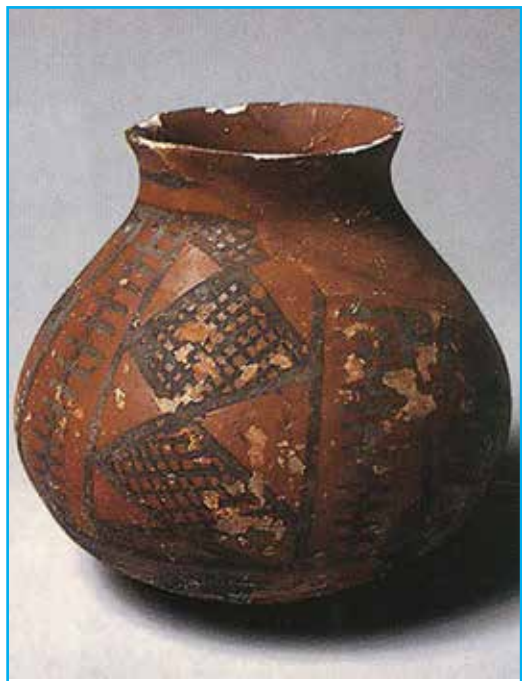
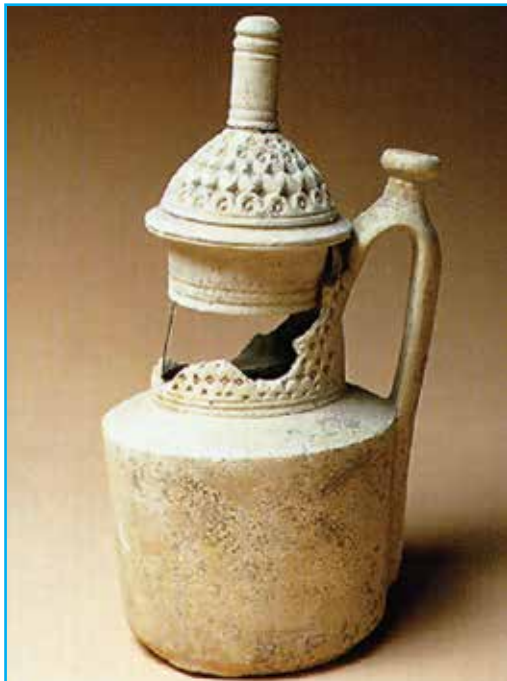
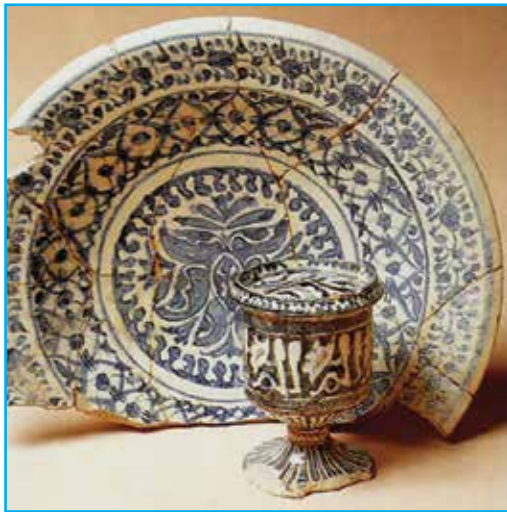

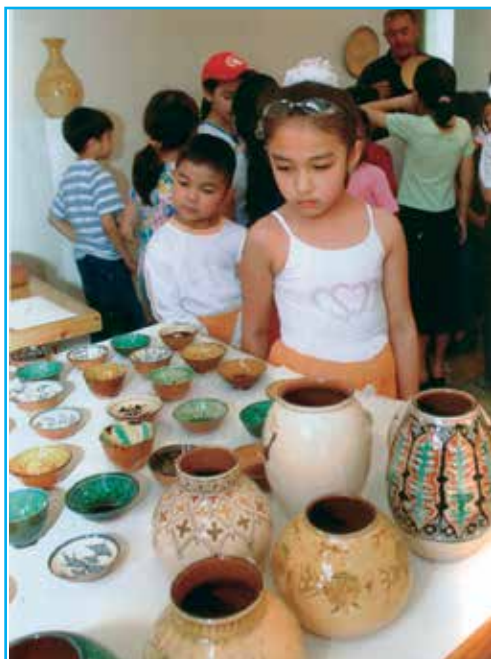

1. Kulolchilik san'ati haqida nimalarni bilasiz?
2. Yuqoridagi buyumlarni bezatishda qanday bezak gullaridan foydalanilganini aniqlang.



## Loydan sopol buyum yasash bosqichlari.

1



Maxsus tuproqdan  
loy tayyorlanadi.

2



Loyga shakl  
beriladi.

3



Buyumga rang va  
bezak beriladi.

4



Maxsus elektr pechda  
quritiladi.



O'qituvchi tomonidan tanlangan uy-ro'zg'or buyumini loydan yasang. Buyumga qanday bezaklar bilan ishlov berishingizni qog'ozda xomaki chizing.



1. Sopol buyumlarni yasash bosqichlarini aytib bering.
2. Uyingizda qanday sopol buyumlardan foydalanasiz? Ularning sifati va afzalliklari nimada?

**Abdurahim Muxtorov** – kulol, mayda shakllar ustadasi, O'zbekiston Respublikasi san'at arbobi. «Choyxonachi», «Beshik», «Xo'ja Nasriddin», «Tuya va bo'taloq» va boshqa milliy o'yinchoqlar yaratgan.



1. Sinfda boshlangan sopol buyum yasashni nihoyasiga yetkazing, quriting va unga turli bezaklar bilan ishlov bering.
- 2\*. O'lkamizdagi kulolchilik san'ati namunalarini toping. Ularning sifati va qanday bezak berilganini aniqlang.





Ma'lumki, ranglar yorug'lik nuri tovlanishidan hosil bo'ladi. Shu sabab narsalarning rangi quyosh charaqlab turgan kunduz kuni va quyosh botayotgan oqshom paytida turlicha bo'ladi. Rassomlar bir xil manzarani kunning turli pallalarida chizishni, ranglarni bor jilosida tasvirlashni xush ko'radilar.



1. Fotosuratlarda kunning qaysi pallalari tasvirlangan? Ular bir-biridan qanday farqlanadi?

Rustam Xudayberganovning «Oqshom» nomli asarini kuzating va uning mazmunini soʻzlab bering.



Rustam Xudayberganov. *Oqshom*.



Quyidagi ranglar ichidan yangi o'rganilgan rang nomlarini aniqlang.



Qizil.



Malla.



Ko'k.



Binafsha.



Qirmizi.



Jigarrang.



Yashil.



Zarg'aldoq.



Pushti.



Sariq.



Havorang.



Qo'ng'ir.



Siyohrang.



Alvonrang.



Moviy.



Oq.



Qora.



Kulrang.





Quyidagi rasmlardan qaysi birida oqshom tasvirlangan? Rasmlarda qanday ranglardan foydalanilganiga e'tibor bering.



Taassurotlaringiz asosida «Oqshom» mavzusi-  
sida rasm ishlang. Bunda siz quyosh nurlarining  
kamayishi natijasida shakllar, ranglar umumiy-  
lashib borishini e'tiborga oling.





1. 128-betdagi rasmlar haqida hikoya qilib bering.
2. Rasmlarda bunday ranglar ishlatilishi sabablarini ayting.



1. «Oqshom» mavzusida rasm ishlashni oxiriga yetkazing.
- 2\*. 127-betda keltirilgan ranglarni eslab qoling va ularning nomlarini yodlang.



B. Ro‘zmetovning «Polvon kanal» asarini kuzating va uni ta’riflab bering.



B. Ro‘zmetov. *Polvon kanal.*

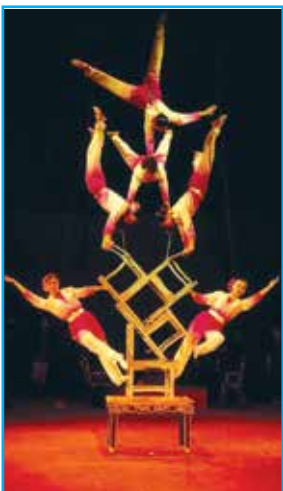

1. Rasmlarda qaysi tomoshalarni ko'ryapsiz?
2. Sirkda yana qanday tomoshalar ko'rgansiz?





## Hayvon o'rgatuvchi haykalini ishlash bosqichlari.

1



2



3



4



5



6



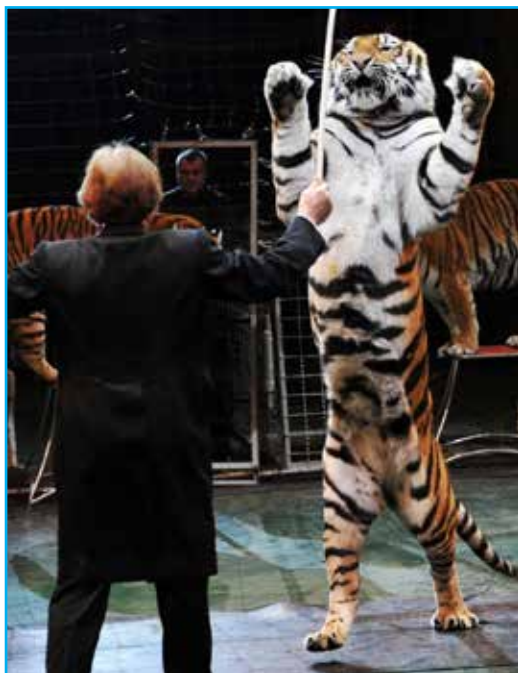
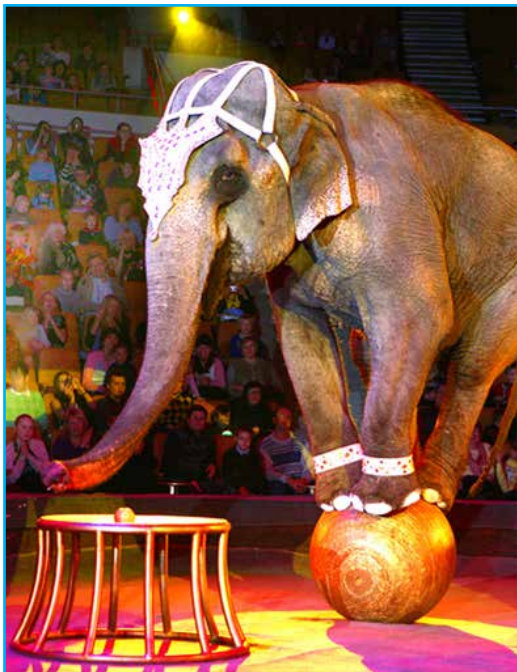



## Yo'lbars haykalini ishlash bosqichlari.

1



2



3



4



Berilgan namunalardan foydalanib, «Hayvon o'rgatuvchi» deb nomlangan haykaltaroshlik kompozitsiyasini tuzing.



1. Haykaltaroshlik kompozitsiyasi nima?
2. Yasalgan haykallardan yana qanday kompozitsiyalar tuzish mumkin.



1. «Hayvon o'rgatuvchi» haykaltaroshlik kompozitsiyasini oxiriga yetkazing.
- 2\*. «Hayvon o'rgatuvchi» mavzusida boshqa haykaltaroshlik kompozitsiyasini ishleng.



33-34

**JONAJON O'LKA**  
**(yakuniy nazorat darsi)**

Berilgan rasmlarni kuzating. Haqiqatan go'zal o'lka-miz bor. Uning chiroyini shoirlar she'rlarda ifodalaydilar, xonandalar qo'shiq qilib kuylaydilar, rassomlar rang-bo'yoqlar yordamida tasvirlaydilar.



I. Otaboyev. *So'qoq.*



E. Bozorov. *Oqtosh manzarasi.*





Yu. Yelizarov. *Kuz.*

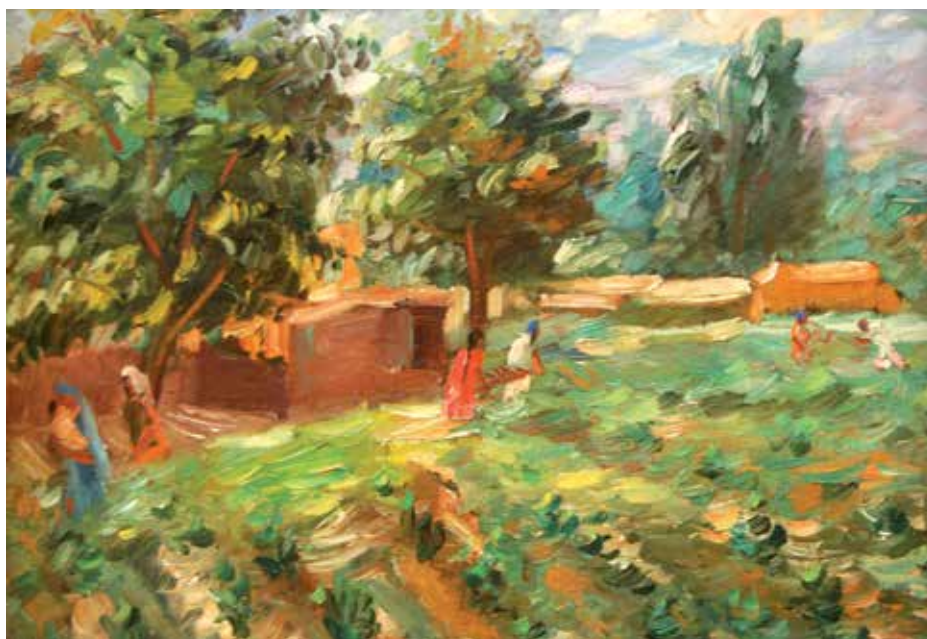

A. Volkov. *Qishloq manzarasi.*

## I. Test savollari:

1. Asosiy ranglar qaysi qatorda berilgan?



2. Qaysi naqshning ikkita bezak guli bor?

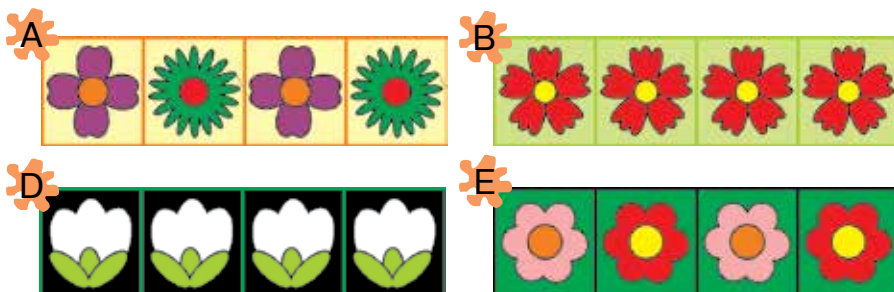

3. Qaysi ranglar juftligi kontrast emas?

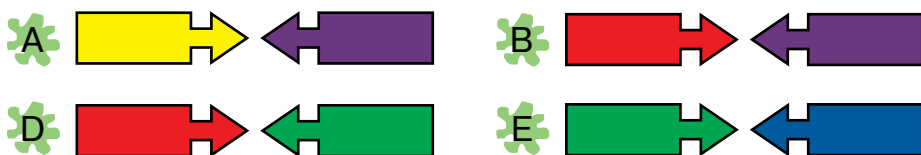

4. Qaysi naqshning foni va bezak guli rangi to'g'ri tanlanmagan?

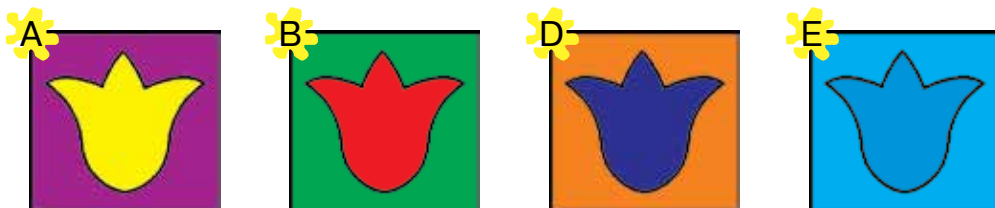

5. Qaysi rasmda relyefli haykal tasvirlangan?



6. Quyida keltirilgan rasmlarni kuzatib, har birining nomini ayting.



1. Applikatsiya.
2. Manzara.

3. Haykal.
4. To'rtburchak naqsh.

7. Cho'l manzarasini tasvirlashda asosan qaysi ranglardan foydalaniladi?

- A B D E  
Iliq ranglar. Asosiy ranglar. Sovuq ranglar. Kontrast ranglar.

8. Qaysi rasm qaysi ertak asosida ishlanganligini aniqlang.



9. Qaysi rasm faqat iliq ranglarda ishlangan?

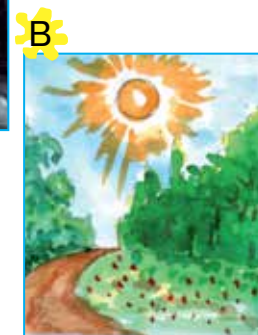

## II. Topshiriq.

Qadri o'quvchi, yil yakunida o'lkamiz tabiati haqida rasm ishlang. Uni bajarish uchun 3-sinf davomida «Tasviriy san'at» darslarida olgan barcha bilim, mahoratingizni ishga soling.



## M U N D A R I J A

Rasm ishlash uchun joy hozirlash  
va narsalarning o'lchamini aniqlash ..... 4

### I CHORAK

1. «O'zbekiston — mening Vatanim» mavzusida rasm ishlash ..... 6
2. «Yoz o'tdi soz» mavzusida rasm ishlash..... 10
3. Atlas matosi uchun naqsh ishlash ..... 13
4. Yo'lsimon shaklda naqsh ishlash..... 19
5. Mevalar rasmini ishlash ..... 26
6. Haykaltaroshlik. Baliq relyefini yasash ..... 30
7. To'rtburchak shaklda naqsh ishlash ..... 34
8. «Tog'da kuz» mavzusida rasm ishlash ..... 40
9. Oraliq nazorat darsi ..... 45

### II CHORAK

10. Tabiiy materiallardan applikatsiya ishlash ... 48
- 11–12. «Kech kuz» mavzusida rasm ishlash ... 54
13. «Toshbaqa bilan chayon» masali asosida rasm ishlash ..... 59



- 14.** «Nasriddin Afandi» mavzusida haykal ishlash .. 63
- 15.** «Dorboz bola» mavzusida rasm ishlash..... 67
- 16.** «O‘lkamizda qish» mavzusida rasm ishlash.. 71
- 17.** Oraliq nazorat darsi..... 75

### III CHORAK

- 18.** «Qishki o‘yinlar» mavzusida rasm ishlash... 78
- 19.** Me‘moriy naqsh ishlash..... 82
- 20.** «Hayvonot bog‘ida» mavzusida rasm ishlash.. 86
- 21.** «Oltin tarvuz» ertagi  
asosida rasm ishlash..... 91
- 22.** Natyurmort rasmini ishlash..... 96
- 23.** «Tulki va turna» ertagi asosida  
haykal ishlash ..... 99
- 24.** «Tennischi» mavzusida rasm ishlash..... 102
- 25.** «Bahor gullari» mavzusida rasm ishlash ..... 105
- 26.** «Navro‘z bayrami» tabriknomasini ishlash ... 110
- 27.** Oraliq nazorat darsi..... 113

### IV CHORAK

- 28.** Doira shaklida naqsh ishlash..... 117
- 29–30.** Kulolchilik. Loydan lagan yasash..... 120
- 31.** «Oqshom» mavzusida rasm ishlash ..... 125
- 32.** «Hayvon o‘rgatuvchi» mavzusida  
haykal ishlash ..... 130
- 33–34.** Jonajon o‘lka (yakuniy nazorat darsi). 136



**MUYASSAR ISOQOVA, RAHIM HASANOV,  
BAHODIR HAYDAROV, ASQARALI SULAYMONOV,  
SAODAT JUMANIYOZOVA, BOBIR AZIMOV**

## **TASVIRIY SAN'AT**

Umumiy o'rta ta'lim maktablarining  
3-sinfi uchun darslik

Toshkent – «Yangiyo'l Poligraf Servis» – 2016  
Nashriyot litsenziyasi AI № 185 10.05.2011 y.

Muharrir – *J. Azimov*

Texnik muharrir – *M. Riksiyev*

Rassom – *B. Abdirov*

Haykaltaroshlar – *A. Rahimov, J. Abduvahabov*

Original-maketdan bosishga ruxsat etildi \_\_\_\_\_. Bichimi  
70x90<sup>1</sup>/16. «Arial» garniturasida. Ofset bosma usulda bosildi.  
Shartli bosma tabog'i 9,0. Nashr bosma tabog'i \_\_\_\_\_. Nusxasi  
\_\_\_\_\_. Buyurtma N\_\_\_\_\_.

«Yangiyo'l poligraf servis» MCHJ bosmaxonasida bosildi.  
112001, Toshkent vil, Yangiyo'l tum., Samarqand ko'chasi, 44.

372.874=512.133(075)  
T25

Tasviriy san'at: Umumiy o'rta ta'lim maktablarining  
3-sinfi uchun darslik / M. Isoqova, R. Hasanov, B. Haydarov,  
A. Sulaymonov, S. Jumaniyozova, B. Azimov. — T.: «Yangiyo'l  
poligraf servis», 2016 – 144 b.

I. Isoqova, Muyassar.

KBK 85.1ya71

## Ijaraga berilgan darslik holatini ko'rsatuvchi jadval

T/r	O'quvchining ismi va familiyasi	O'quv yili	Darslikning olingandagi holati	Sinf rahbarining imzosi	Darslikning topshirilgandagi holati	Sinf rahbarining imzosi
1.						
2.						
3.						
4.						
5.						
6.						

### Darslik ijaraga berilib, o'quv yili yakunida qaytarib olinganda yuqoridagi jadval sinf rahbari tomonidan quyidagi baholash mezonlariga asosan to'ldiriladi:

Yangi	Darslikning birinchi marotaba foydalanishga berilgandagi holati.
Yaxshi	Muqova butun, darslikning asosiy qismidan ajralmagan. Barcha varaqlari mavjud, yirtilmagan, ko'chmagan, betlarida yozuv va chiziqalar yo'q.
Qoniqarli	Muqova ezilgan, birmuncha chizilib, chetlari yedirilgan, darslikning asosiy qismidan ajralish holati bor, foydalanuvchi tomonidan qoniqarli ta'mirlangan. Ko'chgan varaqlari qayta ta'mirlangan, ayrim betlariga chizilgan.
Qoniqarsiz	Muqovaga chizilgan, yirtilgan, asosiy qismdan ajralgan yoki butunlay yo'q, qoniqarsiz ta'mirlangan. Betlari yirtilgan, varaqlari yetishmaydi, chizib, bo'yab tashlangan. Darslikni tiklab bo'lmaydi.